

HPARCHIVE

This vintage Hewlett Packard document was
preserved and distributed by

www.hparchive.com

Please visit us on the web!

Scanned by on-line curator: Jack Hudler

**** For FREE Distribution Only ****

J06-59992A

**TIME INTERVAL
CALIBRATOR**





HEWLETT
PACKARD

OPERATING AND SERVICE MANUAL

J06-59992A

TIME INTERVAL CALIBRATOR

SERIAL PREFIX: 2526A

This manual applies to Serial Prefix 2526A,
unless accompanied by a Manual Change
Sheet indicating otherwise.

© Copyright HEWLETT-PACKARD COMPANY 1985
5301 STEVENS CREEK BOULEVARD, SANTA CLARA, CALIFORNIA 95051

MANUAL PART NUMBER 59992-91094

Printed OCTOBER 1985

CERTIFICATION

Hewlett-Packard Company certifies that this product met its published specifications at the time of shipment from the factory. Hewlett-Packard further certifies that its calibration measurements are traceable to the United States National Bureau of Standards, to the extent allowed by the Bureau's calibration facility, and to the calibration facilities of other International Standards Organization members.

WARRANTY

This Hewlett-Packard instrument product is warranted against defects in material and workmanship for a period of one year from date of shipment. During the warranty period, Hewlett-Packard Company will, at its option, either repair or replace products which prove to be defective.

For warranty service or repair, this product must be returned to a service facility designated by HP. Buyer shall prepay shipping charges to HP and HP shall pay shipping charges to return the product to Buyer. However, Buyer shall pay all shipping charges, duties, and taxes for products returned to HP from another country.

HP warrants that its software and firmware designated by HP for use with an instrument will execute its programming instructions when properly installed on that instrument. HP does not warrant that the operation of the instrument, or software, or firmware will be uninterrupted or error free.

LIMITATION OF WARRANTY

The foregoing warranty shall not apply to defects resulting from improper or inadequate maintenance by Buyer, Buyer-supplied software or interfacing, unauthorized modification or misuse, operation outside of the environmental specifications for the product, or improper site preparation or maintenance.

NO OTHER WARRANTY IS EXPRESSED OR IMPLIED. HP SPECIFICALLY DISCLAIMS THE IMPLIED WARRANTIES OF MERCHANTABILITY AND FITNESS FOR A PARTICULAR PURPOSE.

EXCLUSIVE REMEDIES

THE REMEDIES PROVIDED HEREIN ARE BUYER'S SOLE AND EXCLUSIVE REMEDIES. HP SHALL NOT BE LIABLE FOR ANY DIRECT, INDIRECT, SPECIAL, INCIDENTAL, OR CONSEQUENTIAL DAMAGES, WHETHER BASED ON CONTRACT, TORT, OR ANY OTHER LEGAL THEORY.

ASSISTANCE

Product maintenance agreements and other customer assistance agreements are available for Hewlett-Packard products.

For any assistance, contact your nearest Hewlett-Packard Sales and Service Office. Addresses are provided at the back of this manual.

Table of Contents

Section 1 GENERAL INFORMATION

Page

1-1. INTRODUCTION	1-1
1-2. GENERAL DESCRIPTION	1-1
1-3. SPECIFICATIONS	1-2
1-4. EQUIPMENT SUPPLIED	1-2
1-5. RECOMMENDED TEST EQUIPMENT	1-3



Section 2 INSTALLATION

Page

2-1. INTRODUCTION	2-1
2-2. PREPARATION FOR USE	2-1
2-3. Power Requirements	2-1
2-4. Power-On	2-2
2-5. LOCAL OPERATION/REMOTE OPERATION	2-2
2-6. Setting the HP J06-59992A HP-IB Address	2-2
2-7. HP-IB Interconnections	2-3



Section 3 OPERATING INFORMATION

Page

3-1. INTRODUCTION	3-1
3-2. ADJUSTMENTS	3-1
3-3. OPERATION VERIFICATION	3-1
3-4. AUTOMATED CALIBRATION ROUTINE --USING HP 5370A/B COUNTER	3-3
3-5. AUTOMATED CALIBRATION ROUTINE --USING HP 5363B PROBES	3-6
3-6. TROUBLESHOOTING HINTS AND GENERAL COMMENTS	3-9
3-7. HP-IB PROGRAM LISTINGS	3-9

Section 4 THEORY OF OPERATION

Page

4-1. INTRODUCTION	4-1
4-2. TIME INTERVAL CALIBRATOR	4-1
4-3. A1 VHF Switch Control Board	4-1
4-4. A2 VHF Switch Board	4-1
4-5. Theory of Operation	4-1
4-6. HP-IB COMMAND OPERATION	4-1
4-7. INPUT SIGNAL CONVERSION	4-2
4-8. CALIBRATION WITH AN OFFSET VOLTAGE	4-3
4-9. EXAMPLE OF A NON-ZERO TRIGGER LEVEL MEASUREMENT	4-4
4-10. Functional Block Diagram Theory	4-5
4-11. HANDSHAKE LOGIC	4-5
4-12. BUS LOGIC	4-5
4-13. DECODE LOGIC	4-5

Table of Contents

4-14. REMOTE/LOCAL LOGIC	4-7
4-15. LOCAL LOCKOUT LOGIC	4-7
4-16. RELAY SELECT LOGIC	4-7

Section 5 REPLACEABLE PARTS

Page

5-1. INTRODUCTION	5-1
5-2. PARTS ORDERING	5-1
5-3. COMPONENT LOCATORS	5-9

SAFETY CONSIDERATIONS

GENERAL

This product and related documentation must be reviewed for familiarization with safety markings and instructions before operation.

This product is a Safety Class I instrument (provided with a protective earth terminal).

BEFORE APPLYING POWER

Verify that the product is set to match the available line voltage and the correct fuse is installed. Refer to Section II, Installation.

SAFETY EARTH GROUND

An uninterruptible safety earth ground must be provided from the mains power source to the product input wiring terminals or supplied power cable.

SAFETY SYMBOLS



Instruction manual symbol; the product will be marked with this symbol when it is necessary for the user to refer to the instruction manual.



Indicates hazardous voltages.



Indicates terminal is connected to chassis when such connection is not apparent.



Alternating current.



Direct current.

WARNING

The **WARNING** sign denotes a hazard. It calls attention to a procedure, practice, or the like, which, if not correctly performed or adhered to, could result in personal injury. Do not proceed beyond a **WARNING** sign until the indicated conditions are fully understood and met.

CAUTION

The **CAUTION** sign denotes a hazard. It calls attention to an operating procedure, practice, or the like, which, if not correctly performed or adhered to, could result in damage to or destruction of part or all of the product. Do not proceed beyond a **CAUTION** sign until the indicated conditions are fully understood and met.

SAFETY INFORMATION

WARNING

Any interruption of the protective grounding conductor (inside or outside the instrument) or disconnecting the protective earth terminal will cause a potential shock hazard that could result in personal injury. (Grounding one conductor of a two conductor outlet is not sufficient protection.)

Whenever it is likely that the protection has been impaired, the instrument must be made inoperative and be secured against any unintended operation.

If this instrument is to be energized via an autotransformer (for voltage reduction) make sure the common terminal is connected to the earthed pole terminal (neutral) of the power source.

Instructions for adjustments while covers are removed and for servicing are for use by service-trained personnel only. To avoid dangerous electric shock, do not perform such adjustments or servicing unless qualified to do so.

For continued protection against fire, replace the line fuse(s) only with 250V fuse(s) of the same current rating and type (for example, normal blow, time delay). Do not use repaired fuses or short circuited fuseholders.

1-1. INTRODUCTION

This manual contains operating and service information for the J06-59992A Time Interval Calibrator. Included is the following:

- *** general description of the calibrator
- *** specifications
- *** equipment supplied and recommended test equipment
- *** *installation information*
- *** operating information
- *** automated procedure for determining calibration constants
- *** HP-IB program listings
- *** theory of operation
- *** replaceable parts lists
- *** component locators
- *** schematic diagrams

1-2. GENERAL DESCRIPTION

The J06-59992A is a special instrument used to increase the accuracy of precision time interval measurements. When employed to determine the systematic errors of a particular measurement set-up, the calibrator can provide for absolute accuracy on the order of ± 100 ps when making time interval measurements with the Hewlett-Packard 5370A/B Time Interval Counter. The calibrator can also be used to improve the accuracy of the HP 5363B Time Interval Probes when used in conjunction with the HP 5370A/B counter.

The instrument itself is a linear, passive device which takes a stable input pulse and produces two output pulses that are effectively in phase or 180 degrees out of phase. This provides two identical and coherent signals to the input of a measurement instrument such as a counter. Any time difference measured by the counter in a calibration set-up is a measure of the errors associated with the measurement channels' electrical path lengths and the trigger level timing error of the counter. The resultant computed "calibration constant" is then subtracted from the measurements that follow, thereby removing the effect of systematic errors from the measurement results.

1-3. SPECIFICATIONS



The instrument specifications for the J06-59992A Time Interval Calibrator are listed in Table 1-1.

Table 1-1. J06-59992A Specifications.

Bandwidth: 1 MHz to 200 MHz square wave; 100 kHz to 200 MHz sine wave.

Input Voltage: 5V peak-to-peak, max.

Effective Edge Repeatability: < 10 ps.
(error contributed by J06-59992A)

Insertion Loss: 3dB nominal.

Relay Settling Time: 4 ms nominal.

Output Offset Voltage: Input impedance: 1 Mohm NOMINAL
+/- 10V max @ high impedance output load.
+/- 2V max @ 50 ohm output load.
Settling time: 50 ms NOMINAL.

Voltage Error: +/- 2 mV, max @ high impedance output load
DC Output Resistance: 0.100 ohm, typical.

Power Requirements: 48-66 Hz, 115 or 230 VAC, +10%, -15%; 20 VA maximum.

1-4. EQUIPMENT SUPPLIED

> J06-59992A Time Interval Calibrator

> AC Power Cord

> Documentation:

J06-59992A Operating and Service Manual

Product Note 5370B-2, "Better Than 100 ps Accuracy in HP 5370B Time Interval Measurements Through Bias Error Reduction." HP Publication #02-5952-7770.

1-5. RECOMMENDED TEST EQUIPMENT

For Local Operation:

- > Pulse Generator -- a signal source capable of simulating the signal to be measured.
- > HP 5370A/B Time Interval Counter
- > Oscilloscope -- dual channel, general purpose
- > DC Voltage Source -- (Optional; used to provide offset voltage when not using Time Interval Probes)
- > HP 5363B Time Interval Probes (Optional)

NOTE

The procedures to follow to determine calibration constants using Local Operation are contained in Product Note 5370B-2, "Better Than 100 ps Accuracy in HP 5370B Time Interval Measurements Through Bias Error Reduction."

For Remote Operation:

All equipment listed under Local Operation above, PLUS

- > HP Series 200 Controller such as HP 9836, 9826, 9817*, or 9816*
- > HP-IB Interconnection Cables -- HP 10833A/B/C/D

* These controllers require a separate disc drive such as the HP 9122 for 3 1/2" microfloppy discs or the HP 9125 for 5 1/4" floppy discs.

(This page left intentionally blank)

2-1. INTRODUCTION

This section presents the information needed to prepare the HP J06-59992A Time Interval Calibrator for use. Information to prepare for remote operation using HP-IB (Hewlett-Packard Interface Bus, HP's implementation of IEEE Std. 488-1978) is also included.

2-2. PREPARATION FOR USE

2-3. Power Requirements



The J06-59992A Time Interval Calibrator operates from either 115 or 230 volts, 48 to 66 Hz. Before applying power, the voltage selector switch mounted on the rear panel of the J06-59992A must be set to the correct position (115 or 230) using a small screwdriver, and the correct fuse must be installed. This instrument uses a .2A 250V time-delay (TD) fuse for 115 volt operation or a .1A 250V time-delay (TD) fuse for 230 volt operation. Refer to Table 5-3 in Replaceable Parts for the HP Part Numbers of these fuses.

CAUTION

BEFORE PLUGGING THIS INSTRUMENT INTO THE AC POWER LINES, be sure the correct voltage and fuse have been selected.

WARNING

This is a Safety Class I product (i.e., provided with a protective earth terminal). An uninterruptible safety earth ground must be provided from the Mains power source to the product input wiring terminals, power cord, or supplied power cord set. Whenever it is likely that the protection has been impaired, the instrument must be made inoperative and be secured against any unintended operation. If this instrument is to be energized via an external autotransformer for voltage reduction, make sure that the common terminal is connected to the earthed pole of the power source.

2-4. Power-On



The J06-59992A is energized whenever its power cord is plugged into the appropriate power source. The power indicator on the front panel will light.

WARNING

BEFORE APPLYING POWER TO THE INSTRUMENT, the protective earth terminal of the instrument must be connected to the protective conductor of the (Mains) power cord. The Mains plug shall only be inserted in a socket outlet provided with a protective earth contact. The protective action must not be negated by the use of an extension cord (power cable) without a protective conductor (grounding). Grounding one conductor of a two conductor outlet is not sufficient protection.

2-5. LOCAL OPERATION/REMOTE OPERATION

The HP J06-59992A Time Interval Calibrator is capable of being operated through an external controller as well as in the local mode. The controller used for remote operation must have HP-IB compatibility.

2-6. Setting the HP J06-59992A HP-IB Address

The HP J06-59992A HP-IB instrument address is set with the DIP switch, A2S1, which is accessible through an opening in the rear panel. Set the HP-IB address using switches A1 through A5 (switches A6 and A7 are not used). Setting the switches as shown below will allow proper communication between the controller and the J06-59992A according to the programs provided with this documentation.

SWITCH:	A5	A4	A3	A2	A1	
SETTING:	0	0	1	0	1	= 05 Decimal Equivalent

NOTE

Allowable HP-IB address codes are 00 through 30. If a code other than 05 is used for the J06-59992A, the appropriate lines of the programs must be changed to agree with the different calibrator address before proceeding. (See line 260 in "CAL5370" and "CAL5363" programs.)

2-7. HP-IB Interconnections

The HP-IB system allows interconnection of up to 15 (including the controller) HP-IB compatible instruments. The HP-IB cables have identical "piggyback" connectors on both ends so that several cables can be connected to a single source without special adapters or switch boxes. System components can be connected in virtually any configuration desired. There must be, of course, a path from the controller to every device operating on the bus. Be sure each connector is firmly screwed in place (finger tight) to keep it from working loose during use.

(This page left intentionally blank)

OPERATING INFORMATION

SECTION

3

3-1. INTRODUCTION

This section presents the information needed to operate the HP J06-59992A Time Interval Calibrator. The calibrator is used together with a high performance time interval counter such as the HP 5370A/B. The calibrator helps to determine the errors characteristic of any particular measurement situation. The measured error data is used in a calculation to arrive at a number which represents the contribution of the systematic errors. This number is then subtracted from the measurements that follow, thereby increasing the accuracy of the results by factoring out errors introduced by the elements of the measurement set-up itself.

NOTE

An important element of the documentation for the HP J06-59992A is Product Note 5370B-2, "Better Than 100 ps Accuracy in HP 5370B Time Interval Measurements Through Bias Error Reduction." This Product Note describes the methods for manually determining the calibration constants for time interval, pulse width, and transition time measurement set-ups. It also explains the reasoning behind the mathematical formulas used to arrive at the calibration constants. However, it is not necessary to fully comprehend the mathematical formulas in order to obtain the calibration constants using the automated routines referenced in this section.

3-2. ADJUSTMENTS

There are no adjustments required for the J06-59992A.

3-3. OPERATION VERIFICATION

Description:

This verification test checks the basic operation of the HP J06-59992A Time Interval Calibrator.

Equipment Required:

- > Pulse Generator
- > DC Voltage Source
- > Oscilloscope

HP J06-59992A Time Interval Calibrator
Operating Information

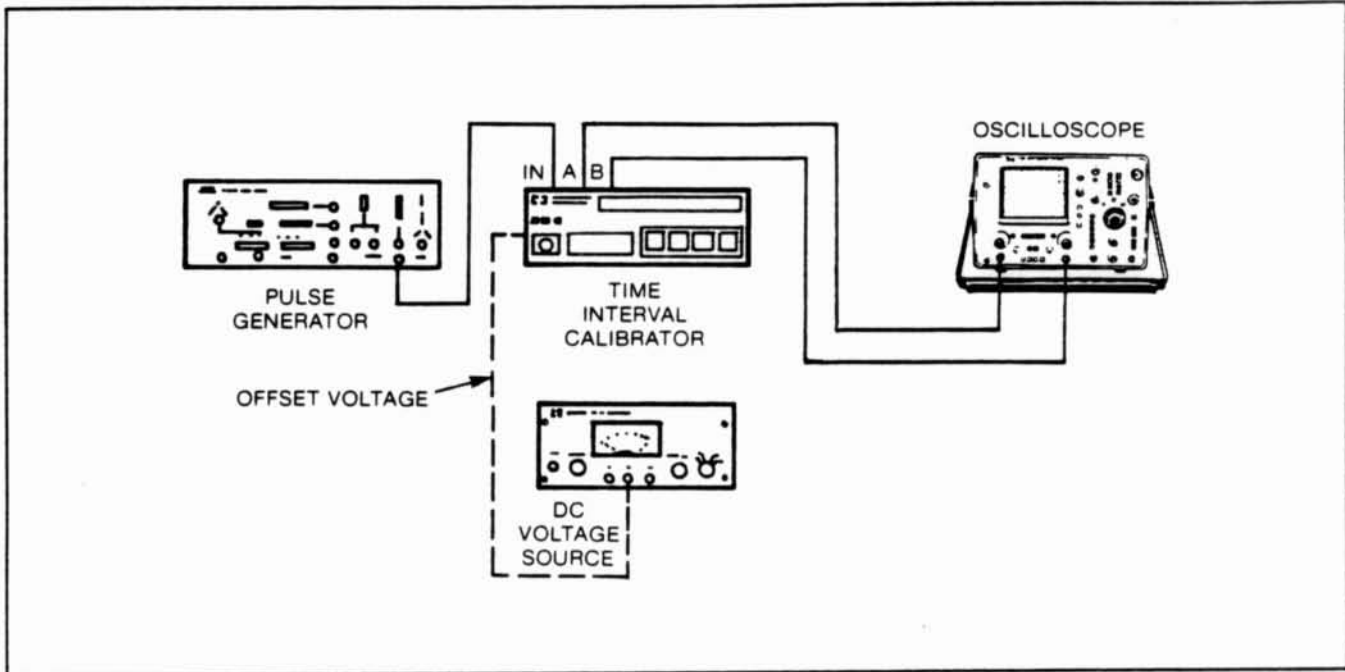

Figure 3-1. Operation Verification Test Set-up.

Procedure:

- a. Set the pulse generator to produce a square wave, 10 MHz signal with an amplitude up to 5 V p-p and a 50% duty cycle.
- b. Connect the pulse generator signal to the J06-59992A Input. Connect the Outputs to Channel A and B of the oscilloscope. Set coupling for both oscilloscope inputs to 50-ohm.
- c. Select pushbutton #1 on the front panel of the J06-59992A and observe the output signals with the oscilloscope.
- d. Verify that the signals at outputs A and B are 10 MHz in-phase signals, with an amplitude of approximately 70% of input, centered at 0.00V, and a 50% duty cycle. There should be no signal breakup or distortion. Note that the reduced output amplitude is due to the nominal 3dB loss of the J06-59992A power-splitters.
- e. Select pushbutton #2 and verify that the signals appear the same as in step d.
- f. Select pushbutton #3 and verify that the signals are now 180 degrees out-of-phase.
- g. Select pushbutton #4 and verify that the signals appear the same as in step f.
- h. Apply a +2V signal from the dc voltage source to the Offset Voltage Input on the rear panel of the J06-59992A and verify that the signals measured on the oscilloscope are both offset from ground by +2V.

- i. Apply a -2V signal to the Offset Voltage Input and observe that the signals measured on the oscilloscope are both offset from ground by -2V.
- j. Disconnect the test equipment from the J06-59992A Time Interval Calibrator.

3-4. AUTOMATED CALIBRATION ROUTINE --USING HP 5370A/B COUNTER

Description:

This routine automatically determines the calibration constants for the 5370A/B counter. In this calibration procedure, known signals from the calibrator are fed into the 5370A/B. Counter readings, which depict measured errors, are represented as "calibration constants." The eight constants generated by the program apply to measurements with SEP and COM counter configurations and with combinations of "+" and "-" slopes.

The calibration signal duty cycle is always at 50%; however, voltage swing, mid-pulse voltage offset, transition rate, and pulse rate can be adjusted by user to simulate actual measurement conditions.

Equipment Required:

- > HP 5370A/B Time Interval Counter
- > DC Voltage Source -- to provide an offset voltage if making measurements at non-zero trigger levels.
- > HP Series 200 Controller such as HP 9836, 9826, 9817*, 9816* with BASIC

*Requires separate disc drive

- > HP-IB Cables

- > Pulse Generator--must be capable of generating a signal which:

1. Simulates the voltage swing X1.5 and the transition rates (rise/fall times) of the desired signal to be measured.
2. Has a 50% duty cycle, approximately, but the duty cycle must not change during the few seconds of calibration.
3. Has a constant rate of at least 1 MHz. User decides the rate at which to calibrate.

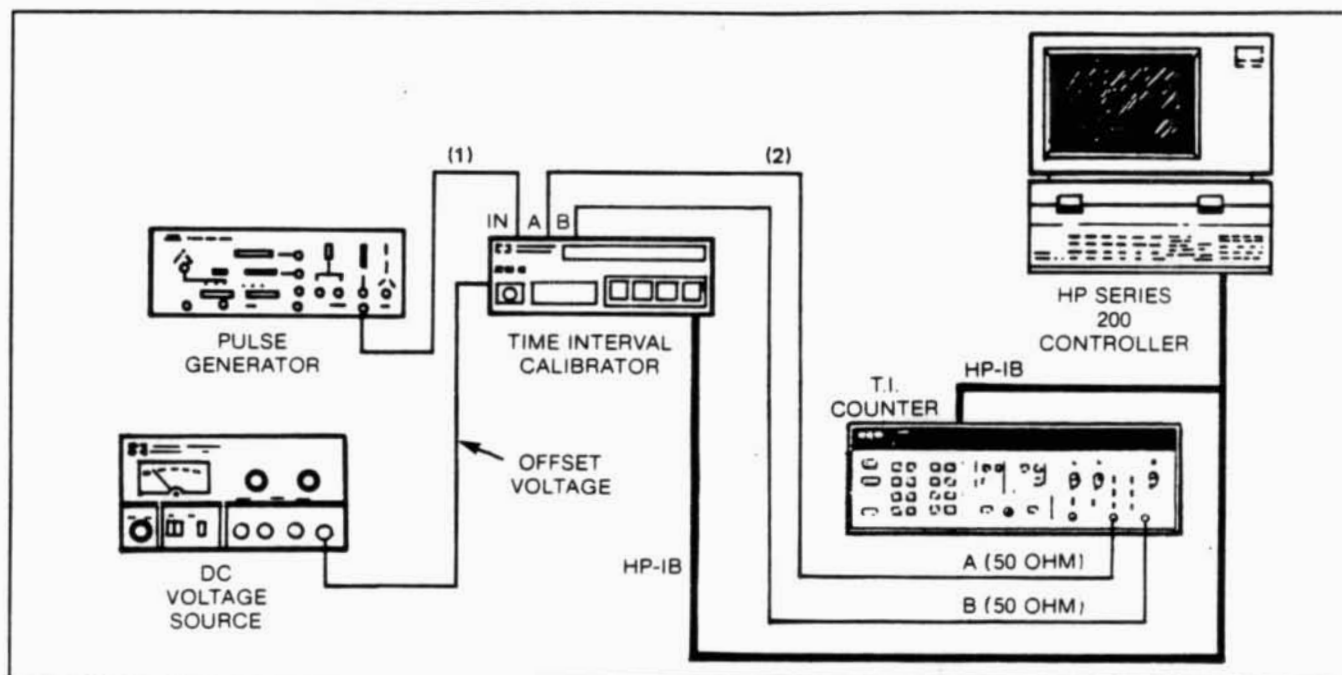

Figure 3-2. Calibration Using the 'CAL5370' Program.

(1) The signal swing at this point from the Pulse Generator should be 1.5 times the desired signal to be measured.

(2) The signals at this point going from the Time Interval Calibrator to the Counter should simulate the actual signal to be measured later.

Procedure:

- a. Connect the HP-IB cables between the J06-59992A, the HP 5370A/B counter, and the controller. Set the HP-IB address of the J06-59992A to 05. Set the HP-IB address of the counter to 07.
- b. Power up the pulse generator and the instruments connected by the HP-IB bus.
- c. Connect a pair of cables from the J06-59992A calibrator outputs A and B to the counter's START and STOP inputs.

NOTE

In order for the calibration to be valid, these same cables must be used for the measurements which follow the calibration routine.

- d. Set counter to SEPARATE, set START and STOP channels to DC, 50 OHM, DIVIDE-BY-1 ATTENUATION, and TRIGGER LEVEL to PRESET.

NOTE

To allow an offset voltage limit of +/- 10V, the counter should be set to 1 Megohm, which means the pulse generator must be a good 50 ohm source, and the counter should be set to Divide-By-10, which also necessitates changing two program lines. Add an exclamation point in front of line 320, and remove the exclamation point from in front of line 330 in "CAL5370."

- e. Set the pulse generator to produce a signal with a 50% duty cycle at a frequency selected by the user. Adjust amplitude to be 1.5 times that of the desired signal.
- f. Connect this signal to the Input of the J06-59992A.
- g. If using an offset voltage, connect this voltage to the Offset Voltage Input on the rear panel of the Time Interval Calibrator. This dc voltage should be identical to the trigger level voltage of the signal to be measured.
- h. Load the "CAL5370" calibration routine program into memory of the controller.
- i. Run the program. The user will need to respond to prompts displayed on the CRT. This involves entering the offset voltage value used and operating the SEP/START COM switch on the counter.
- j. The display provides a summary of the calibration constants to be subtracted from the counter measurements, depending on the type of measurement to be made. Also included is a list of the consistency parameters. These provide a measure of the typical experimental error that can be expected when using the calibration constants.

Example of results:

CAL5370

CALIBRATION CONSTANTS:

(TO BE SUBTRACTED FROM COUNTER READINGS)

TIME INTERVAL + TO +	-18 ps
TIME INTERVAL - TO -	-73 ps
TIME INTERVAL + TO -	-52 ps
TIME INTERVAL - TO +	-48 ps
WIDTH + TO -	235 ps
WIDTH - TO +	250 ps
RISE-TIME SKEW	168 ps
FALL-TIME SKEW	107 ps

CALIBRATED AT 50 MHz with OFFSET @ .5 VOLTS

CONSISTENCY:

TI ++,--: -1 ps
TI +-,+-: 16 ps
WIDTH: 2 ps

3-5. AUTOMATED CALIBRATION ROUTINE --USING HP 5363B PROBES

Description:

This routine automatically determines the calibration constants for the HP 5370A/B counter when used with the HP 5363B Time Interval Probes. In this calibration procedure, known signals from the calibrator are fed into the 5370A/B. Counter readings, which depict measured errors, are represented as "calibration constants." The eight constants generated by the program apply to measurements with SEP and COM counter configurations and with combinations of "+" and "-" slopes.

The calibration signal duty cycle is always at 50%; however, voltage swing, mid-pulse voltage offset, transition rate, and pulse rate can be adjusted by user to simulate actual measurement conditions.

Equipment Required:

- > HP 5370A/B Time Interval Counter
- > HP 5363B Time Interval Probes
- > HP Series 200 Controller such as HP 9836, 9826, 9817*, 9816* with BASIC

*Requires separate disc drive

- > HP-IB Cables
- > Pulse Generator--must be capable of generating a signal which:
 1. Simulates the voltage swing X1.5 and the transition rates (rise/fall times) of the desired signal to be measured.
 2. Has a 50% duty cycle, approximately, but the duty cycle must not change during the few seconds of calibration.
 3. Has a constant rate of at least 1 MHz. User decides the rate at which to calibrate.

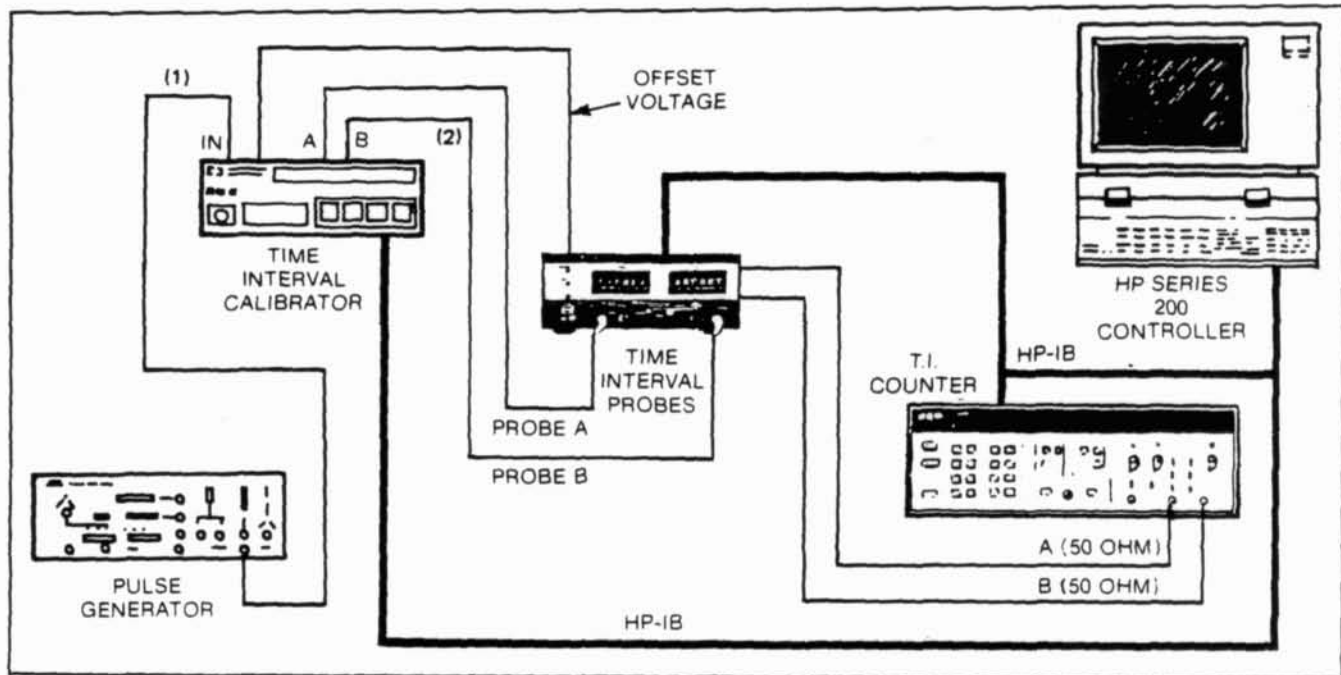

Figure 3-3. Calibration Using the 'CAL5363' Program.

(1) The signal swing at this point from the Pulse Generator should be 1.5 times the desired signal to be measured.

(2) The signals at this point going from the Time Interval Calibrator to the Counter should simulate the actual signal to be measured later.

Procedure:

a. Connect the HP-IB cables between the J06-59992A, the HP 5370A/B counter, HP 5363B Time Interval Probes, and the Controller. Set the HP-IB address of the J06-59992A to 05. Set the HP-IB address of the HP 5363B Time Interval Probes to 04, and the address of the counter to 07.

b. Power up the pulse generator and the instruments connected by the HP-IB bus.

c. Connect a pair of cables from the 5363B Probe outputs to the counter's START and STOP inputs.

NOTE

In order for the calibration to be valid, these same cables must be used for the measurements which follow the calibration routine.

d. The Time Interval Probes should be pre-calibrated for trigger-level accuracy as explained in the HP 5363B Operating and Service Manual. (Insert probes into 5363B and press "Level" switch down for several seconds.)

e. Connect a 50-ohm load and a Time Interval Probe to each of the J06-59992A A and B Outputs using the special tee adapters available with the Time Interval Probes.

f. Set counter to SEPARATE, set both START and STOP channels to DC, 50 OHM, DIVIDE-BY-1 ATTENUATION, and TRIGGER LEVEL to PRESET.

NOTE

To allow an offset voltage limit of +/- 10V, the 50 ohm loads at the Outputs of the J06-59992A should be removed. In this case, the pulse generator must be a good 50 ohm source.

g. Set the pulse generator to produce a signal with a 50% duty cycle at a frequency selected by the user. Adjust amplitude to be 1.5 times that of the desired signal.

h. Connect this signal to the Input of the J06-59992A.

i. Connect the Trigger Level Output START voltage from the Time Interval Probes rear panel to the Offset Voltage Input on the rear panel of the Time Interval Calibrator. This dc voltage, set through the program, should be identical to the trigger level voltage of the signal to be measured. The Time Zero knob can be set to any position, but it must remain at that setting during calibration and the measurements which follow.

NOTE

When using the 5363B Time Interval Probes to produce the offset voltage, the trigger level of the counter must be set to 0.00 V. The program automatically sets the trigger level of the counter to this value regardless of the Probes trigger level.

j. Load the "CAL5363" calibration routine program into memory of the controller.

k. Run the program. The user will need to respond to a prompt displayed on the CRT. This involves entering the offset voltage value used.

l. The display provides a summary of the calibration constants to be subtracted from the measurements of the probe/counter combination depending on the type of measurement to be made. Also included is a list of the consistency parameters. These provide a measure of the typical experimental error that can be expected when using the calibration constants.

Example of results:

CAL5363

CALIBRATION CONSTANTS:

(TO BE SUBTRACTED FROM COUNTER READINGS)

TIME INTERVAL + TO +	74 ps
TIME INTERVAL - TO -	46 ps
TIME INTERVAL + TO -	224 ps
TIME INTERVAL - TO +	-86 ps
WIDTH + TO -	152 ps
WIDTH - TO +	13 ps
RISE-TIME SKEW	-142 ps
FALL-TIME SKEW	-239 ps

CALIBRATED AT 50 MHz with OFFSET @ -1.3 VOLTS

CONSISTENCY:

TI ++,--: 23 ps

TI +-,+-: -42 ps

WIDTH: 22 ps

3-6. TROUBLESHOOTING HINTS AND GENERAL COMMENTS

A typical calibration takes about 7 seconds. If the programs should "hang up", check for the following:

- > Verify that all electrical connections between test instruments are correct.
- > Verify that all test instruments are set properly.
- > Verify that the instrument HP-IB addresses correspond to those in the HP-IB programs.
- > Verify that the trigger level is not greater than +/- 2V for a 50 ohm output load.
- > When using a dc voltage source to provide an offset voltage it must agree with the voltage level entered by the user at the program prompt.

3-7. HP-IB PROGRAM LISTINGS

Following are the listings of the two programs referenced in this section to run the automated calibration routines with the HP J06-59992A Time Interval Calibrator.

a. Calibration Routine using HP 5370A/B

File "CAL5370"

b. Calibration Routine using HP 5363B Time Interval Probes

File "CAL5363"

(This page left intentionally blank)

```

101 RE-STORE "CAL5370"
20 PRINT "CAL5370 REV 12 JUN 85"
30 ! ORIG 6 DEC 84
40 ! THIS PROGRAM EXECUTES THE CALIBRATION ALGORITHM DESCRIBED IN D. CHU'S
50 ! PAPER "CALIBRATION OF SYSTEMATIC ERRORS IN PRECISION TIME-INTERVAL
60 ! COUNTERS", INTERNATIONAL TEST CONFERENCE, PHILADELPHIA, 1985;
70 !
80 ! SET-UP PROCEDURE
90 ! 1) CONNECT A PULSE SOURCE TO THE INPUT OF CALIBRATOR, 3 DB LARGER
100 ! THAN THE DESIRED SIGNAL TO BE MEASURED AND APPROXIMATELY THE
110 ! SAME RISE/FALL TIMES, -50% DUTY-CYCLE, STABLE 1 TO 100 MHZ.
120 ! 2) CONNECT A PAIR OF CABLES FROM CALIBRATOR OUTPUTS A & B
130 ! TO COUNTER START & STOP INPUTS RESPECTIVELY
140 ! (NOTE: CABLE MISMATCHES ARE INCLUDED IN THE CALIBRATION CONSTANTS,
150 ! AND SAME CABLES SHOULD BE USED LATER FOR DOING MEASUREMENTS;
160 ! ALSO "CABLES" INCLUDE LINEAR, PASSIVE OR ACTIVE PROBES)
170 ! 3) SET COUNTER TO SEPERATE; DC/50 ohms/X1/PRESET to BOTH CHANNELS
180 ! 4) HP-IB ADDRESSES: COUNTER-707, CALIBRATOR-705
190 ! 5) CONNECT A PRECISE OFFSET VOLTAGE SOURCE TO THE OFFSET INPUT; ENTER
200 ! THE EXACT SAME VALUE WHEN PROMPTED. DEFAULT IS 0.00 VOLT
210 !
220 !
230 ! _____
240 ! INITIALIZATION
250 Ctr=707 !HP-IB ADDRESSES
260 Cal=705
270 Ps=1.E+12
280 OUTPUT Cal;"B1"
290 OUTPUT Ctr;"FN1"
300 INPUT "Type in OFFSET (volts); set counter to ""SEP"" and ""CONTINUE""",Ofs
310 OUTPUT Ctr;"ST6" !CLEARS ANY PREVIOUS REFERENCE (IF DESIRED)
320 Level=Ofs !THIS LINE USED WITH X1 ATTENUATION
330 !Level=Ofs*.1 !THIS LINE USED WITH X10 ATTENUATION
340 OUTPUT Ctr;"FN2TR" !SET COUNTER TRIGGER LEVEL TO MATCH OFFSET
350 OUTPUT Ctr USING ""TA"",SD.DD";Level
360 OUTPUT Ctr USING ""TO"",SD.DD";Level
370 OUTPUT Ctr;"FN4GT2MD2MR" !MEASURE FREQUENCY/PERIOD
380 OUTPUT Ctr;"MR"
390 ENTER Ctr;Per !PERIOD/FREQUENCY
400 !
410 ! _____
420 DISP " TIME-INTERVAL CALIBRATION IN PROGRESS"
430 OUTPUT Ctr;"FN1ST1SS3AR2EA0MR"
440 OUTPUT Ctr;"SRSALSO1MR"
450 OUTPUT Ctr;"MR"
460 T1=FNTi(Per,Ctr) ! + + DIRECT
470 OUTPUT Ctr;"SA2SO2MR"
480 OUTPUT Ctr;"MR"
490 T2=FNTi(Per,Ctr) ! - - DIRECT
500 OUTPUT Cal;"B2"
510 WAIT .004
520 OUTPUT Ctr;"MR"
530 T3=FNTi(Per,Ctr) ! - - SWAPPED
540 OUTPUT Ctr;"SALSO1MR"
550 OUTPUT Ctr;"MR"
560 T4=FNTi(Per,Ctr) ! + + SWAPPED
570 OUTPUT Cal;"B3"
580 WAIT .004
590 OUTPUT Ctr;"SALSO2MR"
600 OUTPUT Ctr;"MR"
610 T5=FNTi(Per,Ctr) ! + - DIRECT
620 OUTPUT Ctr;"SA2SO1MR"
630 OUTPUT Ctr;"MR" !
640 T6=FNTi(Per,Ctr) ! - + DIRECT
650 OUTPUT Cal;"B4"
660 WAIT .004

```

(Page 3-11)

```

670 OUTPUT Ctr;"MR"
680 T7=FNTi(Per,Ctr) ! - + SWAPPED
690 OUTPUT Ctr;"SA1SO2MR"
700 OUTPUT Ctr;"MR"
710 T8=FNTi(Per,Ctr) ! + - SWAPPED
720 ! END TIME-INTERVAL CALIBRATION
730 !
740 !
750 OUTPUT Ctr USING ""TA"",SD.DD";Level*.5 !START COM DIVIDES BY 2 @ 50 OHM
760 OUTPUT Ctr USING ""TO"",SD.DD";Level*.5 !START COM DIVIDES BY 2 @ 50 OHM
770 DISP "Set counter to ""START COM"", and ""CONTINUE"" program"
780 PAUSE
790 DISP " WIDTH, RISE/FALL SKEW CALIBRATION IN PROGRESS"
800 !SINCE COUNTER INPUTS ARE COMMON, THIS MEANS ONLY THE START-CHANNEL IS
810 !BEING USED FOR MEASUREMENTS. THE STOP-CHANNEL SERVES ONLY AS A 50-ohm
820 !TERMINATION FOR THE CALIBRATOR B-OUTPUT
830 !IF NOTHING ELSE IS CHANGED, CALIBRATOR SHOULD BE ON B4
840 OUTPUT Ctr;"AR1SA1SO2MR"
850 OUTPUT Ctr;"MR"
860 ENTER Ctr;W4 ! + - WIDTH SWAPPED
870 OUTPUT Ctr;"SA2SO1MR"
880 OUTPUT Ctr;"MR"
890 ENTER Ctr;W3 ! - + WIDTH SWAPPED
900 OUTPUT Cal;"B3"
910 WAIT .004
920 OUTPUT Ctr;"MR"
930 ENTER Ctr;W2 ! - + WIDTH DIRECT
940 OUTPUT Ctr;"SA1SO2MR"
950 OUTPUT Ctr;"MR"
960 ENTER Ctr;W1 ! + - WIDTH DIRECT
970 OUTPUT Cal;"B1"
980 WAIT .004
990 OUTPUT Ctr;"AR2SA1SO1MR"
1000 OUTPUT Ctr;"MR"
1010 ENTER Ctr;R ! + + RISE TIME SKEW
1020 OUTPUT Ctr;"SA2SO2MR"
1030 OUTPUT Ctr;"MR"
1040 ENTER Ctr;F ! - - FALL TIME SKEW
1050!
1060! END WIDTH RISE/FALL SKEW CALIBRATION
1070!
1080 OUTPUT Ctr;"MD1" ! RETURN COUNTER TO CYCLING MODE
1090! BEGIN CALCULATE CALIBRATION CONSTANTS
1100 Cpp=.5*(T1+T4)
1110 Cnn=.5*(T2+T3)
1120 Cpn=.5*(T5+T8)
1130 Cnp=.5*(T6+T7)
1140 IF W1>Per THEN W1=W1-Per
1150 IF W2>Per THEN W2=W2-Per
1160 IF W3>Per THEN W3=W3-Per
1170 IF W4>Per THEN W4=W4-Per
1180 Wpn=.5*(W1+W4-Per)
1190 Wnp=.5*(W2+W3-Per)
1200 ! END CALCULATE CALIBRATION CONSTANTS
1210 !
1220 !
1230 ! BEGIN CALCULATE CONSISTENCY PARAMETERS (Page 3-12)
1240 Pp=.5*(T1-T4)
1250 Nn=.5*(T2-T3)
1260 Pn1=.5*(T5-T8)
1270 Pn2=.5*(T6-T7)
1280 Wpn1=W1-.5*Per-.25*(W1-W2+W3-W4)
1290 Wpn2=W4-.5*Per+.25*(W1-W2+W3-W4)
1300 Wnp1=W2-.5*Per+.25*(W1-W2+W3-W4)
1310 Wnp2=W3-.5*Per-.25*(W1-W2+W3-W4)
1320 ! END CALCULATE CONSISTENCY PARAMETERS

```

```

1330 PRINT "                CALIBRATION CONSTANTS:"
1340 PRINT "      (TO BE SUBTRACTED FROM COUNTER READINGS)"
1350 PRINT USING "####"    TIME INTERVAL + TO + " ", DDDDDD, " " ps"""; Cpp*Ps
1360 PRINT USING "####"    TIME INTERVAL - TO - " ", DDDDDD, " " ps"""; Cnn*Ps
1370 PRINT USING "####"    TIME INTERVAL + TO - " ", DDDDDD, " " ps"""; Cpn*Ps
1380 PRINT USING "####"    TIME INTERVAL - TO + " ", DDDDDD, " " ps"""; Cnp*Ps
1390 PRINT USING "####"    WIDTH + TO - " ", DDDDDD, " " ps"""; Wpn*Ps
1400 PRINT USING "####"    WIDTH - TO + " ", DDDDDD, " " ps"""; Wnp*Ps
1410 PRINT USING "####"    RISE-TIME SKEW " ", DDDDDD, " " ps"""; R*Ps
1420 PRINT USING "####"    FALL-TIME SKEW " ", DDDDDD, " " ps"""; F*Ps
1430 PRINT "CALIBRATED AT ";INT(1.E-6/Per+.5);" MHz with OFFSET @ ";Ofs;" VOLTS"
1440 PRINT "CONSISTENCY:"
1450 PRINT "TI ++,--: ";INT(Ps*(Pp-Nn)*.5);"ps"
1455 PRINT "TI +-,+-: ";INT(Ps*(Pn1-Pn2)*.5);"ps"
1460 PRINT "WIDTH : ";INT(Ps*(Wpn1-Wpn2)*.5);"ps"
1470 !PRINT "WIDTH -+: ";INT(Ps*(Wnpl-Wnp2)*.5);"ps"
1480 DISP "END CALIBRATION"
1490 END
1500 !
1510 !
1520 DEF FNTi(P,Ctr)          !RETURNS T.I.
1530 ENTER Ctr;T
1540 IF ABS(T)<.5*P THEN 1570 !WITH PROPER PERIOD COMPLEMENT
1550 OUTPUT Ctr;"PCMR"
1560 ENTER Ctr;T
1570 RETURN T
1580 FNEND

```

```

10! RE-STORE "CAL5363"
20 PRINT "CAL5363 REV 19 JUL 85"
30 !ORIG 11 DEC 84
40 ! THIS PROGRAM EXECUTES THE CALIBRATION ALGORITHM DESCRIBED IN D. CHU'S
50 ! PAPER "CALIBRATION OF SYSTEMATIC ERRORS IN PRECISION TIME-INTERVAL
60 ! COUNTERS", INTERNATIONAL TEST CONFERENCE, PHILA, 1985, WITH HP5363B
70 ! SET-UP PROCEDURE
80 ! 1) CONNECT A PULSE SOURCE TO THE INPUT OF CALIBRATOR, 3 DB LARGER
90 ! THAN THE DESIRED SIGNAL TO BE MEASURED AND APPROXIMATELY THE
100 ! SAME RISE/FALL TIMES, -50% DUTY-CYCLE, STABLE 1 TO 100 MHz.
110 ! 2) CONNECT A PAIR OF CABLES FROM 5363B PROBE OUTPUTS TO
120 ! COUNTER START & STOP INPUTS
130 ! (NOTE: THE SAME CABLES MUST BE USED LATER TO DO MEASUREMENTS
140 ! FOR CALIBRATION TO BE VALID)
150 ! 3) PROBES SHOULD BE PRE-CALIBRATED FOR TRIGGER-LEVEL ACCURACY
160 ! IN ACCORDANCE WITH HP5363B MANUAL (INSERT PROBES TO 5363 AND PUSH
170 ! SWITCH TO "LEVEL" MOMENTARILY)
180 ! 4) TERMINATE CALIBRATOR OUTPUTS A & B WITH 50 ohm AND INSERT PROBES
190 ! A AND B WITH TWO TEE'S; (MUST HAVE 50 ohm SOURCE IF NO 50 ohm LOAD)
200 ! 5) SET COUNTER TO SEPERATE; DC/50 ohms/X1/PRESET to BOTH CHANNELS
210 ! 6) CONNECT 5363 TRIG LEVEL OUTPUT (A or B) TO CALIBRATOR OFFSET INPUT
220 ! 7) HP-IB ADDRESSES: COUNTER-707, CALIBRATOR-705, PROBE-704
230 !
240 !-----
250 Ctr=707 !HP-IB ADDRESSES
260 Cal=705
270 Probe=704
280 Ps=1.E+12 !CONSTANT
290 OUTPUT Ctr;"FN1"
300 INPUT "TYPE IN OFFSET (-9.99 TO 9.99 volts @ Hi Z; -2 TO +2 V @ 50 OHMS)",V
310 OUTPUT Ctr;"ST6" !CLEARS ANY PREVIOUS REFERENCE
320 Level$=VAL$(1000+INT(ABS(100*V)+.5)) !A TRICK TO GET LEADING 0
330 Level$="+"&Level$[2,4] !TRADE LEADING "1" FOR "+"
340 IF V<0 THEN Level$="-"&Level$[2,4] !TRADE "+" FOR "-"
350 OUTPUT Probe;"GA"&Level$&"USRB"&Level$&"US"!SET TRIG LEVEL (2-PROBE CAL)
360 OUTPUT Ctr;"FN2TRTA0.00" !SET COUNTER TO SUIT PROBE OUTPUTS
370 OUTPUT Ctr;"T00.00"
380 OUTPUT Ctr;"SRSALS01"
390 OUTPUT Ctr;"FN4GT2MR" !MEASURE FREQUENCY (PERIOD)
400 ENTER Ctr;Per
410 OUTPUT Ctr;"FN1ST1SS3AR2EA0MD2MR" !SET COUNTER FOR T.I.
420 ENTER Ctr;Pfff !DUMMY READ TO CLEAR PIPELINE
430 !
440 !-----
450 DISP " TIME-INTERVAL CALIBRATION IN PROGRESS"
460 OUTPUT Cal;"B1"
470 OUTPUT Ctr;"MR"
480 T1=FNTi(Per,Ctr) ! + + SLOPE DIRECT
490 OUTPUT Probe;"GADSRBDS"
500 OUTPUT Ctr;"MR"
510 T2=FNTi(Per,Ctr) ! - - SLOPE DIRECT
520 OUTPUT Cal;"B2"
530 WAIT .004
540 OUTPUT Ctr;"MR"
550 T3=FNTi(Per,Ctr) ! - - SLOPE SWAPPED
560 OUTPUT Probe;"GAUSRBUS"
570 OUTPUT Ctr;"MR"
580 T4=FNTi(Per,Ctr) ! + + SLOPE SWAPPED
590 OUTPUT Cal;"B3"
600 WAIT .004
610 OUTPUT Probe;"GAUSRBDS"
620 OUTPUT Ctr;"MR"
630 T5=FNTi(Per,Ctr) ! + - SLOPE DIRECT (Page 3-14)
640 OUTPUT Probe;"GADSRBUS"
650 OUTPUT Ctr;"MR"
660 T6=FNTi(Per,Ctr) ! - + SLOPE DIRECT

```

```

670 OUTPUT Cal;"B4"
680 WAIT .004
690 OUTPUT Ctr;"MR"
700 T7=FNTi(Per,Ctr) ! - + SLOPE SWAPPED
710 OUTPUT Probe;"GAUSRBDS"
720 OUTPUT Ctr;"MR"
730 T8=FNTi(Per,Ctr) ! + - SLOPE SWAPPED
740 ! END TIME-INTERVAL CALIBRATION
750 !
760 !

---

770 DISP " WIDTH, RISE/FALL SKEW CALIBRATION IN PROGRESS"
780 !SINGLE PROBE MEASUREMENTS (PROBE-A)
790 !FOR PROBE-B CALIBRATION, REPLACE A BY B IN PROBE COMMANDS IN THIS SECTION
800 !FOR EXAMPLE,"GAUSRADS" IS CHANGED TO "GBUSRBDs"
810 !IF NOTHING ELSE IS CHANGED, CALIBRATOR SHOULD BE ON B4
820 OUTPUT Ctr;"AR1MR"
830 OUTPUT Probe;"GAUSRADS"
840 WAIT .004 ! PROBE-A CAL (ONE-PROBE)
850 OUTPUT Ctr;"MR"
860 ENTER Ctr;W4 ! + - WIDTH SWAPPED
870 OUTPUT Probe;"GADSRAUS"
880 OUTPUT Ctr;"MR"
890 ENTER Ctr;W3 ! - + WIDTH SWAPPED
900 OUTPUT Cal;"B3"
910 WAIT .004
920 OUTPUT Ctr;"MR"
930 ENTER Ctr;W2 ! - + WIDTH DIRECT
940 OUTPUT Probe;"GAUSRADS"
950 OUTPUT Ctr;"MR"
960 ENTER Ctr;W1 ! + - WIDTH DIRECT
970 OUTPUT Cal;"B1"
980 WAIT .004
990 OUTPUT Ctr;"AR2MR"
1000 OUTPUT Probe;"GAUSRAUS"
1010 OUTPUT Ctr;"MR"
1020 R=FNTi(Per,Ctr) ! + + PROBE-A (RISE)
1030 OUTPUT Probe;"GADSRADS"
1040 OUTPUT Ctr;"MR"
1050 F=FNTi(Per,Ctr) ! - - PROBE-A (FALL)
1060! END WIDTH RISE/FALL CALIBRATION
1070!
1080!

---

1090 OUTPUT Probe;"GAUSRBUS" !BACK TO 2-PROBES TO THERMO EQUILIZE
1100 OUTPUT Ctr;"MD1" !RETURN COUNTER TO CYCLING MODE
1110!
1120! BEGIN CALCULATE CALIBRATION CONSTANTS
1130 Cpp=.5*(T1+T4)
1140 Cnn=.5*(T2+T3)
1150 Cpn=.5*(T5+T8)
1160 Cnp=.5*(T6+T7)
1170 IF W1>Per THEN W1=W1-Per
1180 IF W2>Per THEN W2=W2-Per
1190 IF W3>Per THEN W3=W3-Per
1200 IF W4>Per THEN W4=W4-Per
1210 Wpn=.5*(W1+W4-Per)
1220 Wnp=.5*(W2+W3-Per)
1230 ! END CALCULATE CALIBRATION CONSTANTS
1240 !
1250 !
1260 ! BEGIN CALCULATE CONSISTENCY PARAMETERS (Page 3-15)
1270 Pp=.5*(T1-T4)
1280 Nn=.5*(T2-T3)
1290 Pn1=.5*(T5-T8)
1300 Pn2=.5*(T6-T7)
1310 Wpn1=W1-.5*Per-.25*(W1-W2+W3-W4)
1320 Wpn2=W4-.5*Per+.25*(W1-W2+W3-W4)

```

```

1330 Wnp1=W2-.5*Per+.25*(W1-W2+W3-W4)
1340 Wnp2=W3-.5*Per-.25*(W1-W2+W3-W4)
1350 !           END CALCULATE CONSISTENCY PARAMETERS
1360 !
1370 !
1380 !
1390 PRINT "           CALIBRATION CONSTANTS:"
1400 PRINT "           (TO BE SUBTRACTED FROM COUNTER READINGS)"
1410 Ps=1.E+12
1420 PRINT USING ""           TIME INTERVAL + TO + "", DDDDDD, "" ps"";Cpn*Ps
1430 PRINT USING ""           TIME INTERVAL - TO - "", DDDDDD, "" ps"";Cnn*Ps
1440 PRINT USING ""           TIME INTERVAL + TO - "", DDDDDD, "" ps"";Cpn*Ps
1450 PRINT USING ""           TIME INTERVAL - TO + "", DDDDDD, "" ps"";Cnp*Ps
1460 PRINT USING "" PROBE-A   WIDTH + TO - "", DDDDDD, "" ps"";Wpn*Ps
1470 PRINT USING "" PROBE-A   WIDTH - TO + "", DDDDDD, "" ps"";Wnp*Ps
1480 PRINT USING "" PROBE-A   RISE-TIME SKEW "", DDDDDD, "" ps"";R*Ps
1490 PRINT USING "" PROBE-A   FALL-TIME SKEW "", DDDDDD, "" ps"";F*Ps
1500 Freq=INT(1.E-6/Per+.5)
1510 PRINT "CALIBRATION PERFORMED AT ";Freq;" MHz @ OFFSET = ";V;" volts"
1520 PRINT "CONSISTENCY:"
1530 PRINT "TI ++,--: ";INT((Pp-Nn)*.5*Ps+.5);"ps"
1540 PRINT "TI +-,+ : ";INT((Pn1-Pn2)*.5*Ps+.5);"ps"
1550 PRINT "WIDTH   : ";INT((Wpn1-Wpn2)*Ps*.5+.5);"ps"
1560 ! "WIDTH -+ : ";INT((Wnp1-Wnp2)*.5*Ps+.5);"ps"
1570 PRINT ""
1580 DISP "END CALIBRATION"
1590 END
1600 !
1610 !
1620 DEF FNTi(P,Ctr)           !RETURNS T.I.
1630 ENTER Ctr;T
1640 IF ABS(T)<.5*P THEN 1670 !WITH PROPER PERIOD COMPLEMENT
1650 OUTPUT Ctr;"PCMR"
1660 ENTER Ctr;T
1670 RETURN T
1680 FNEND

```

THEORY OF OPERATION

SECTION

4

4-1. INTRODUCTION

This section explains the basic operation of the HP J06-59992A Time Interval Calibrator.

4-2. TIME INTERVAL CALIBRATOR

4-3. A1 VHF Switch Control Board

The majority of the components on the A1 board make possible the HP-IB operation of the Time Interval Calibrator. In addition, the board contains the Power Supply, which provides +12V, -12V, and +5V, and the Relay Select Logic to drive the A2 Switch Board.

4-4. A2 VHF Switch Board

This board contains offset voltage circuitry, the relays, the two power-splitters, and the HP-IB address switch.

4-5. Theory of Operation

4-6. HP-IB COMMAND OPERATION

The Hewlett-Packard Time Interval Calibrator can be operated either manually or remotely using HP-IB commands. The commands "B1", "B2", "B3", and "B4" correspond to the front panel switches #1, #2, #3, and #4, respectively.

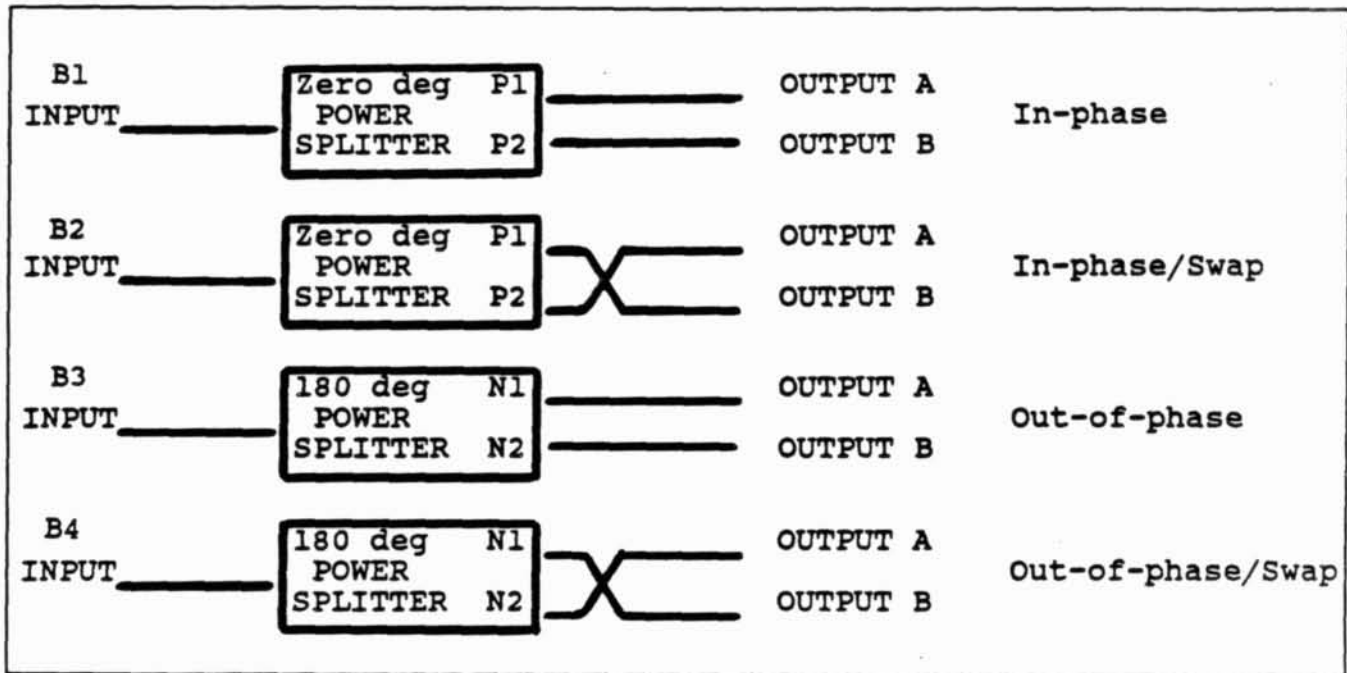

Figure 4-1. HP-IB Command Summary.

4-7. INPUT SIGNAL CONVERSION

The zero degree power-splitter divides the input signal into two nearly in-phase output signals, P1 and P2. Command "B1" routes the input signal from P1 to Output A and P2 to Output B; "B2" routes the input from P1 to Output B and P2 to Output A. Similarly, the 180-degree power-splitter divides the input into two nearly out-of-phase signals, N1 and N2. Command "B3" routes the input signal from N1 to Output A and N2 to Output B; "B4" routes the input from N1 to Output B and N2 to Output A. Refer to Figure 4-1 for a diagram illustrating the effect of the HP-IB commands.

The commands "B1-B4", (or switches 1-4 if manually operated), result in four binary states defined by the two bits arriving on A2J4 pin 4 and pin 6. The bit from pin 4, via buffers in A2U1 energizes the appropriate relays A2K1 and A2K2, routing the incoming signal from A2J1 to the desired power-splitter. The outputs of the selected splitter are fed to A2K3 where they are connected to Outputs A and B directly, or reversed through a cross-over K3 relay arrangement. Note that the input signal to the splitters and the output signals from the splitters are ac-coupled via blocking capacitors A2C1, C8, and C9. Table 4-1 summarizes the J06-59992A operation.

Table 4-1. Relay and Switch Operation of HP J06-59992A.

Switch (man)	HP-IB (remote)	J4 pin 4	J4 pin 6	Splitter used	K1	K2	K3	Output A	Output B
					coils				
1	B1	H	L	T2	OFF	OFF	ON	P1	P2
2	B2	H	H	T2	OFF	OFF	OFF	P2	P1
3	B3	L	H	T1	ON	ON	OFF	N1	N2
4	B4	L	L	T1	ON	ON	ON	N2	N1

4-8. CALIBRATION WITH AN OFFSET VOLTAGE

When time interval calibration is to be done at a particular trigger level voltage, the calibrator A and B output signals must be biased to the same voltage to simulate the signal to be measured. This is accomplished by applying a voltage equal to the desired trigger-level to connector A2J3 on the rear panel of the J06-59992A.

A feedback circuit made up of operational amplifiers (A2U3 and U4) and current sources (A2U2 and U5) make it possible to bias both the A and B calibrator outputs to match a dc voltage appearing at the Offset Voltage Input, A2J3. This "offset" voltage appears on the "+" input of operational amplifier A2U3. The "-" input of U3 senses the dc voltage of the applied bias voltage signal on the output side of blocking capacitor C8, via R13. The difference voltage is amplified, filtered, and controls the current sources A2U2A and U2B with outputs on pins 1 and 7. The feedback loop establishes the output voltage at C8 to be equal to the input offset voltage. A maximum of 40 mA can be sourced by A2U2B or sunk by U2A before saturation. Similarly, voltage at C9 is sensed by R14 and fed back to A2U4. Current sources U5C and U5D ensure the voltage at C9 will be equal to the input offset voltage. Through relay K3, voltages at C8 and C9 are connected to outputs A and B.

With this arrangement, Outputs A and B can be biased up to +/- 2 volts for 50-ohm loads or +/- 10 volts for high impedance loads. In the absence of any input offset voltage, A2R7 establishes the "input" voltage as ground, and no bias will appear at the outputs.

4-9. EXAMPLE OF A NON-ZERO TRIGGER LEVEL MEASUREMENT

Signal to be measured: 10 MHz, 1.0V pulses with mid-pulse at 0.5V.

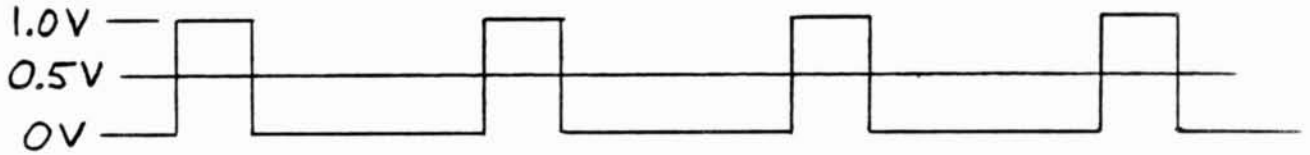

Signal from the pulse generator: 10 MHz, 1.5V square wave

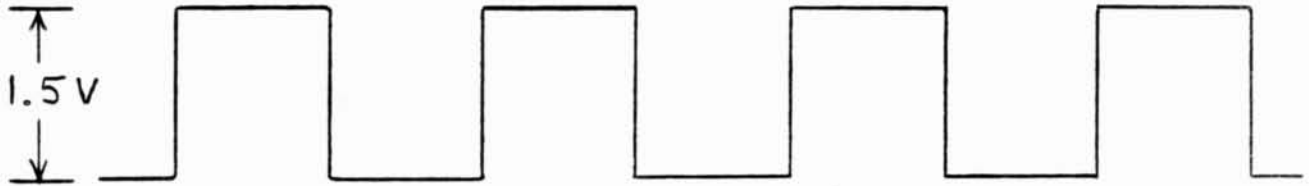

Signal from the time interval calibrator: 10 MHz, 1.0V square wave, with a 0.5V offset and an approximate 50% duty cycle.

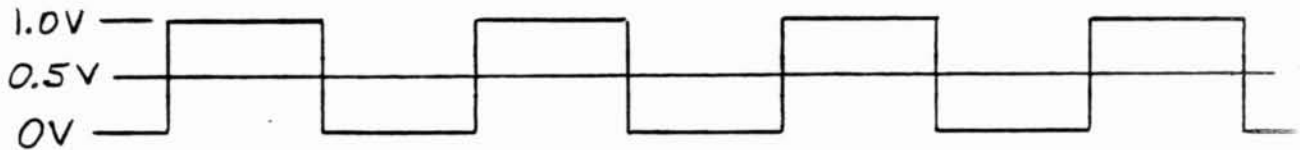

Source of Offset Voltage:

FOR THE HP 5370A/B COUNTER AND THE HP 5363B TIME INTERVAL PROBES COMBINATION

5363B Time Interval Probes--Take the 0.5V from the rear panel START Trigger Level Output and connect it to the Offset Voltage Input of the J06-59992A (user response to software prompt sets the voltage level from the probes). The 5370A/B trigger level is set to 0.00V.

OR

FOR THE HP 5370A/B COUNTER WITHOUT THE TIME INTERVAL PROBES

DC Voltage Source--Connect 0.5V from the dc voltage source to the Offset Voltage Input of the J06-59992A. Set the 5370A/B to a 0.50V trigger level for both the START and STOP channels (user response to software prompt sets the trigger level).

4-10. Functional Block Diagram Theory

Figure 4-2 illustrates the functional block diagram for the HP J06-59992A Time Interval Calibrator. The J06-59992A consists of six major circuit groups: Handshake Logic, Bus Logic, Decode Logic, Remote/Local Logic, Local Lockout Logic, and Relay Select Logic.

4-11. HANDSHAKE LOGIC

The three-wire handshake lines to the Handshake Logic circuits synchronize the operation of the J06-59992A. The lines are: Ready for Data (RFD), Data Valid (DAV), and Data Accepted (DAC). The handshake logic processes the DAV signal and produces the Handshake Out (HSOUT) signal for use by the Bus Logic and the Local Lockout Logic. The DAV signal and the Handshake Enable (HSENABLE) signal combine to output the RFD and DAC signals on the bus. The basic purposes of this logic is to signal the other J06-59992A circuits that the Data Input/Output (DIO) lines contain a character for possible processing and to interface the circuits to the HP Interface Bus three-wire handshake system.

4-12. BUS LOGIC

The Bus Logic accepts inputs from the DIO lines and the Multiple Response Enable (MRE) signal from the Interface Bus. These inputs, in conjunction with the HSOUT signal, enable the Remote/Local Logic and the Local Lockout Logic. In addition, the Bus Logic processes the relay state codes and relay select codes present on the DIO lines, and combines them with the HSOUT and REMOTE signals to output the CLK and CLK signals to the Decode Logic.

The Bus Logic serves the additional function, in conjunction with the Remote/Local Logic, of placing the J06-59992A into remote operation or taking it out of remote operation on command from instructions on the Interface Bus.

4-13. DECODE LOGIC

The Decode Logic receives the CLK and CLK signals from the Bus Logic and receives relay select codes and relay state codes from the DIO lines. These signals are decoded and output to the Relay Select Logic to select switch B and to connect switch B to one of two power-splitters and a switch-over relay. The CLK B signal selects switch B, BIT1 selects power-splitter A2T1 or T2, and BIT2 selects the straight-through or cross-over path through relay A2K3.

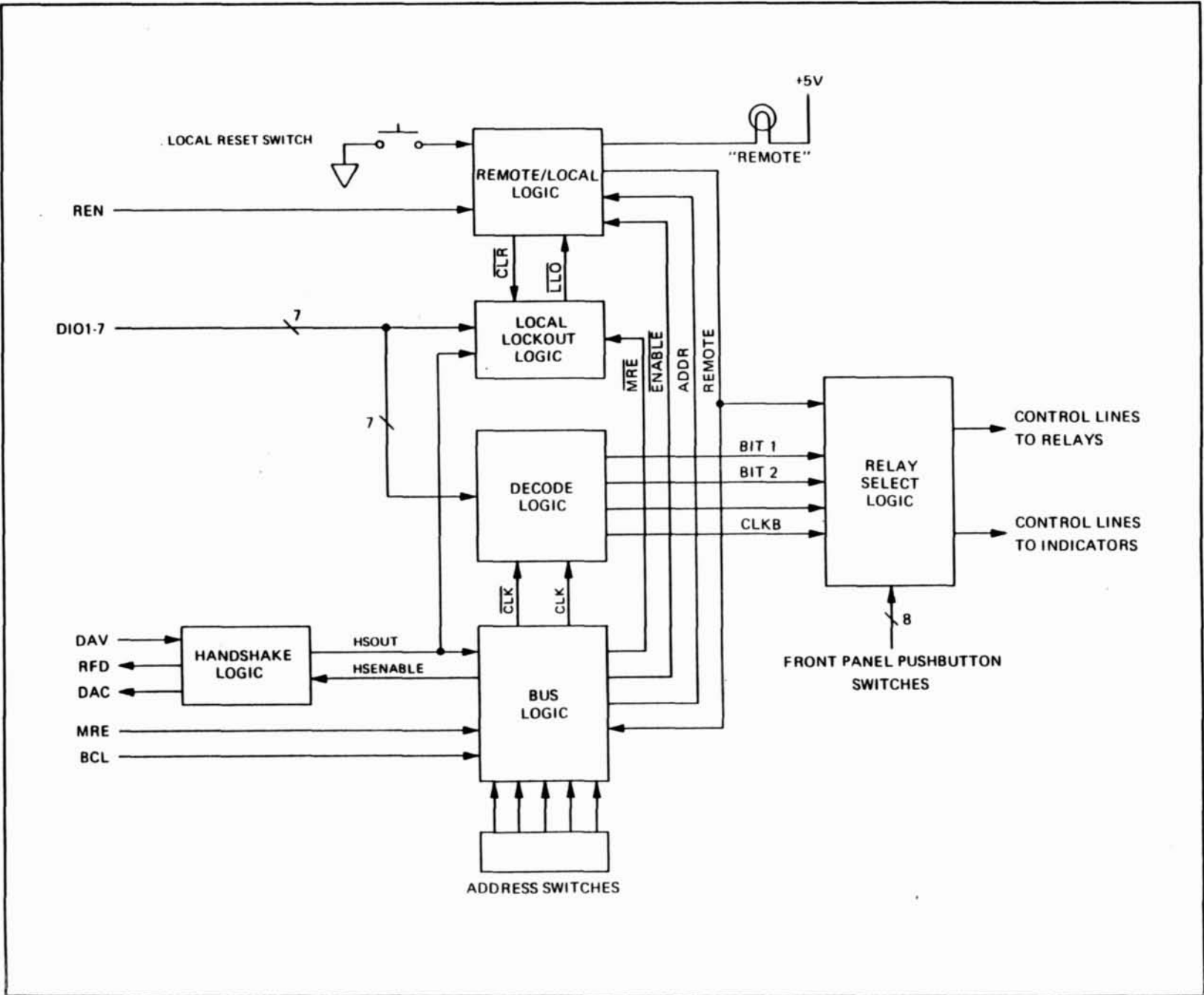

Figure 4-2. J06-59992A Functional Block Diagram.

4-14. REMOTE/LOCAL LOGIC

The Remote/Local Logic receives the Remote Enable (REN) signal from the Interface Bus along with the ENABLE and ADDR signals from the Bus Logic to produce the REMOTE signal. This action puts the J06-59992A in remote operation. When the REMOTE signal is removed (by closing the LOCAL/RESET switch or setting REN high) the J06-59992A is taken out of remote operation. The LOCAL/RESET switch is disabled and cannot take the J06-59992A out of remote operation when the Local Lockout (LLO) signal is received from the Local Lockout Logic.

NOTE

When the REMOTE indicator is illuminated, the J06-59992A front-panel pushbutton switches are disabled. This indicator does not imply that the switches are presently being changed remotely. This indicator may be illuminated even though the J06-59992A is not listening to the bus, e.g., the J06-59992A automatically unaddresses itself whenever MRE is low and the code present on the DIO lines is not its own listen address code.

4-15. LOCAL LOCKOUT LOGIC

The Local Lockout Logic locks the J06-59992A in remote operation by disabling the LOCAL/RESET switch with the LLO signal. The function of this logic is to hold the J06-59992A in remote until the REN signal on the Interface Bus is high to return it to local operation. The logic monitors the DIO lines for the ASCII character DC1 which is processed along with the MRE and HSOUT signals to produce LLO. LLO is cleared by the CLR signal from the Remote/Local Logic. The Local Lockout Logic will lock the J06-59992A in remote operation only when the unit is already in remote. If the J06-59992A is not in remote, this logic will have no effect on the operation or programming.

4-16. RELAY SELECT LOGIC

The Relay Select Logic controls the state of the B switches. The state is determined by which of the power-splitters is connected through which path of the cross-over relay to output connectors A and B. Control is accomplished by signals from the Decode Logic (in remote) or by front panel pushbutton switches (in local). For remote control the REMOTE signal must be high and for local control the REMOTE signal must be low.

(This page left intentionally blank)

REPLACEABLE PARTS

SECTION

5

5-1. INTRODUCTION

This section contains a listing of the replaceable parts for the J06-59992A Time Interval Calibrator. The parts lists are followed by the component locators for the A1 and A2 board assemblies. The parts lists are organized as follows:

- > **Table 5-1** -- A1 Board Assembly Replaceable Parts
- > **Table 5-2** -- A2 Board Assembly Replaceable Parts
- > **Table 5-3** -- Chassis and Miscellaneous Parts
- > **Table 5-4** -- Cabinet Parts

The format for the parts lists is as follows:

- > **Reference Designation** -- helps identify a specific part using the component locators in this section.
- > **HP Part Number** -- identifies a part according to the Hewlett-Packard part inventory system.
- > **Qty** -- specifies the quantity of a particular part used in the instrument.
- > **Description** -- a short summary of the relevant part information.

5-2. PARTS ORDERING

To order a part listed in the replaceable parts tables, quote the Hewlett-Packard part number, indicate the quantity required, and address the order to the nearest Hewlett-Packard office.

**HP J06-59992A Time Interval Calibrator
Replaceable Parts**

Table 5-1. A1 Replaceable Parts.

Reference Designation	HP Part Number	Qty	Description
A1	59992-60001	1	VHF SWITCH CONTROL BOARD ASSEMBLY
A1C1	0180-2101	1	CAP-FXD 4000UF +75-10% 15VDC AL
A1C2	0180-1701	1	CAP-FXD 6.8UF +-20% 6VDC TA
A1C3	0180-2382	2	CAP-FXD 1500UF +75-10% 30VDC AL
A1C4	0140-0149	1	CAP-FXD 470PF +-5% 300VDC MICA
A1C5	0160-4084	2	CAP-FXD .1UF +-20% 50VDC CER
A1C6	0180-2382		CAP-FXD 1500UF +75-10% 30VDC AL
A1C7	0140-0192	2	CAP-FXD 68PF +-5% 300VDC MICA
A1C8	0140-0192		CAP-FXD 68PF +-5% 300VDC MICA
A1C9	0160-3879	4	CAP-FXD .01UF +-20% 100VDC CER
A1C10	0160-3879		CAP-FXD .01UF +-20% 100VDC CER
A1C11	0160-3879		CAP-FXD .01UF +-20% 100VDC CER
A1C12	0160-3879		CAP-FXD .01UF +-20% 100VDC CER
A1C13	0160-4084		CAP-FXD .1UF +-20% 50VDC CER
A1C14	0180-1735	1	CAP-FXD .22UF +-10% 35VDC TA
A1CR1	1901-0040	1	DIODE-SWITCHING 30V 50MA 2NS DO-35
A1CR2	1901-0029	6	DIODE-POWER RECT 600V 750MA DO-29
A1CR3	1901-0029		DIODE-POWER RECT 600V 750MA DO-29
A1CR4	1901-0029		DIODE-POWER RECT 600V 750MA DO-29
A1CR5	1901-0029		DIODE-POWER RECT 600V 750MA DO-29
A1CR6	1901-0029		DIODE-POWER RECT 600V 750MA DO-29
A1CR7	1901-0029		DIODE-POWER RECT 600V 750MA DO-29
A1DS1	2140-0043	2	LAMP-INCAND 1730 6VDC 40MA T-1-3/4-BULB
A1DS2	2140-0043		LAMP-INCAND 1730 6VDC 40MA T-1-3/4-BULB
A1DS3-			NOT ASSIGNED
A1DS6			
A1DS7	2140-0311	4	LAMP-INCAND 7333 5VDC 60MA T-1-3/4-BULB
A1DS8	2140-0311		LAMP-INCAND 7333 5VDC 60MA T-1-3/4-BULB
A1DS9	2140-0311		LAMP-INCAND 7333 5VDC 60MA T-1-3/4-BULB
A1DS10	2140-0311		LAMP-INCAND 7333 5VDC 60MA T-1-3/4-BULB
A1J1	1251-3283	1	CONNECTOR 24-PIN FEM MICRO-RIBBON
A1J2	1200-0473	1	SOCKET-IC 16-CONT DIP-SLDR
A1Q1	1854-0071	1	TRANSISTOR NPN SI PD=300MW FT=200MHZ
A1R1	1810-0136	2	NETWORK-RESISTOR 10-SIP MULTI-VALUE
A1R2	1810-0136		NETWORK-RESISTOR 10-SIP MULTI-VALUE
A1R3	1810-0041	1	NETWORK-RESISTOR 9-SIP 2.7K OHM X 8
A1R4	0683-2725	1	RESISTOR 2.7K 5% .25W
A1R5	0683-1215	3	RESISTOR 120 5% .25W

Table 5-1. A1 Replaceable Parts. (Continued)

Reference Designation	HP Part Number	Qty	Description	
A1R6	0683-1215	4	RESISTOR 120 5% .25W	
A1R7	0683-2035		RESISTOR 20K 5% .25W	
A1R8	0683-2035		RESISTOR 20K 5% .25W	
A1R9	0683-2035		RESISTOR 20K 5% .25W	
A1R10	0683-5125		RESISTOR 5.1K 5% .25W	
A1R11	0683-2035	3	RESISTOR 20K 5% .25W	
A1R12	0683-1025		RESISTOR 1K 5% .25W	
A1R13	0683-1025		RESISTOR 1K 5% .25W	
A1R14	0683-1025		RESISTOR 1K 5% .25W	
A1R15	1810-0055		1	NETWORK-RESISTOR 9-SIP 10.0K OHM X 8
A1R16	0683-1215		RESISTOR 120 5% .25W	
A1S1A		1	NOT ASSIGNED	
A1S1B	3101-0572		SWITCH-PB 4 STATION 15.88MM C-C SPACING	
A1T1	9100-4485	1	TRANSFORMER-POWER 115/230V 48-66HZ	
A1TP1	0360-0124	4	CONNECTOR-SGL CONT-PIN .04-IN-BSC-SZ RD	
A1TP2	0360-0124		CONNECTOR-SGL CONT-PIN .04-IN-BSC-SZ RD	
A1TP3	0360-0124		CONNECTOR-SGL CONT-PIN .04-IN-BSC-SZ RD	
A1TP4	0360-0124		CONNECTOR-SGL CONT-PIN .04-IN-BSC-SZ RD	
A1U1	1820-1207	1	IC TTL LS NAND 8-INP **SN74LS30N	
A1U2	1820-1197	4	IC TTL LS NAND QUAD 2-INP **SN74LS00N	
A1U3	1820-1416	3	IC TTL LS INV HEX 1-INP **SN74LS14N	
A1U4	1820-0904	1	IC COMPTR TTL L MAGTD 5-BIT **93L24PC	
A1U5	1820-1415	1	IC TTL LS NAND DUAL 4-INP **SN74LS13N	
A1U6	1820-1197		IC TTL LS NAND QUAD 2-INP **SN74LS00N	
A1U7	1820-1416	1	IC TTL LS INV HEX 1-INP **SN74LS14N	
A1U8	1820-1202	2	IC TTL LS NAND TPL 3-INP **SN74LS10N	
A1U9	1820-1202		IC TTL LS NAND TPL 3-INP **SN74LS10N	
A1U10	1820-0515	1	IC MV TTL RETRIG/RESET DUAL **MC8602P	
A1U11	1820-1112	3	IC TTL LS D-TYPE POS-EDGE **SN74LS74AN	
A1U12	1820-1209	1	IC BFR TTL LS NAND QUAD 2-INP**SN74LS38N	
A1U13	1820-1416		IC TTL LS INV HEX 1-INP **SN74LS14N	
A1U14	1820-1112		IC TTL LS D-TYPE POS-EDGE **SN74LS74AN	
A1U15			NOT USED	
A1U16			NOT USED	
A1U17	1820-1197		IC TTL LS NAND QUAD 2-INP **SN74LS00N	
A1U18	1820-1112		IC TTL LS D-TYPE POS-EDGE **SN74LS74AN	
A1U19	1820-0621		IC BFR TTL NAND QUAD 2-INP **SN7438N	
A1U20			NOT USED	
A1U21	1820-1197		IC TTL LS NAND QUAD 2-INP **SN74LS00N	
A1U22	1820-1199	1	IC INV TTL LS HEX **SN74LS04N	
A1U23	1820-1204	1	IC TTL LS NAND DUAL 4-INP **SN74LS20N	
A1U24	1820-1211	1	IC TTL LS EXCL-OR QUAD 2-INP**SN74LS86N	

Table 5-1. A1 Replaceable Parts. (Continued)

Reference Designation	HP Part Number	Qty	Description
A1U25	1826-0099	1	IC V RGLTR-FXD-POS 12V TO-220 **7812UC
A1U26	1826-0122	1	IC V RGLTR-FXD-POS 5V TO-220 **7805UC
A1U27	1826-0221	1	IC V RGLTR-FXD-NEG 12V TO-220 **79112CT
MISCELLANEOUS A1 PARTS			
MP1	59307-00006	1	BKT-ANNUN
MP2	05330-40002	1	BLOCK ANNUN
	0380-0906	6	STANDOFF-RVT-ON .1-IN-LG 6-32-THD
	1205-0349	3	HEAT SINK SGL PLSTC-PWR-CS

Table 5-2. A2 Replaceable Parts.

Reference Designation	HP Part Number	Qty	Description
A2	59992-60002	1	VHF SWITCH BOARD ASSEMBLY
A2C1	0160-4535	3	CAP-FXD 1UF +-10% 50VDC CER
A2C2	0160-3875	6	CAP-FXD 22PF +-5% 200VDC CER
A2C3	0160-3875		CAP-FXD 22PF +-5% 200VDC CER
A2C4	0160-4557	2	CAP-FXD .1UF +-20% AXIAL CER
A2C5	0160-3875		CAP-FXD 22PF +-5% 200VDC CER
A2C6	0160-3875		CAP-FXD 22PF +-5% 200VDC CER
A2C7	0160-4557		CAP-FXD .1UF +-20% AXIAL CER
A2C8	0160-4535		CAP-FXD 1UF +-10% 50VDC CER
A2C9	0160-4535		CAP-FXD 1UF +-10% 50VDC CER
A2C10	0160-4389	4	CAP-FXD 100PF +-30% RADIAL CER
A2C11	0160-4389		CAP-FXD 100PF +-30% RADIAL CER
A2C12	0160-4389		CAP-FXD 100PF +-30% RADIAL CER
A2C13	0160-4389		CAP-FXD 100PF +-300% RADIAL CER
A2C14	0180-0210	3	CAP-FXD 3.3UF +-20% 15VDC TA
A2C15	0180-0210		CAP-FXD 3.3UF +-20% 15VDC TA
A2C16	0180-2818	4	CAP-FXD 2.2UF +-20% 35VDC TA
A2C17	0180-2818		CAP-FXD 2.2UF +-20% 35VDC TA
A2C18	0180-2818		CAP-FXD 2.2UF +-20% 35VDC TA
A2C19	0180-2818		CAP-FXD 2.2UF +-20% 35VDC TA
A2C20	0180-0210		CAP-FXD 3.3UF +-20% 15VDC TA
A2C21	0160-3875		CAP-FXD 22PF +-5% 200VDC CER
A2C22	0160-3875		CAP-FXD 22PF +-5% 200VDC CER
A2CR1	1901-0050	3	DIODE SI GP 30V 50MA
A2CR2	1901-0050		DIODE SI GP 30V 50MA
A2CR3	1901-0050		DIODE SI GP 30V 50MA
A2J1	1250-1453	4	CONNECTOR-RF BNC FEM PC 50-OHM
A2J2	1200-0638	1	SOCKET-IC 14-PIN DIP
A2J3	1250-1453		CONNECTOR-RF BNC FEM PC 50-OHM
A2J4	1200-0473	1	SOCKET-IC 16-PIN-DIP
A2J5	1250-1453		CONNECTOR-RF BNC FEM PC 50-OHM
A2J6	1250-1453		CONNECTOR-RF BNC FEM PC 50-OHM
A2K1	0490-1507	1	RF RELAY OMRON 12V **GSY-154PDC12
A2K2	0490-0508	2	RELAY 2C 12VDC-COIL .5A 28VDC DPDT
A2K3	0490-0508		RELAY 2C 12VDC-COIL .5A 28VDC DPDT
A2R1	0757-0458	2	RESISTOR 51.1K 1% .125
A2R2	0698-3153	6	RESISTOR 3.83K 1% .125W
A2R3	0698-3153		RESISTOR 3.83K 1% .125W
A2R4	0698-3153		RESISTOR 3.83K 1% .125W
A2R5	0757-0458		RESISTOR 51.1K 1% .125W

Table 5-2. A2 Replaceable Parts. (Continued)

Reference Designation	HP Part Number	Qty	Description
A2R6	0757-0442	4	RESISTOR 10K 1% .125W
A2R7	0698-8827	1	RESISTOR 1M 1% .125W
A2R8	0698-3153		RESISTOR 3.83K 1% .125W
A2R9	0757-0442		RESISTOR 10K 1% .125W
A2R10	0698-3153		RESISTOR 3.83K 1% .125W
A2R11	0698-3401	2	RESISTOR 215 1% .125W
A2R12	0698-3401		RESISTOR 215 1% .125W
A2R13	0757-0442		RESISTOR 10K 1% .125W
A2R14	0757-0442		RESISTOR 10K 1% .125W
A2R15	0698-3153		RESISTOR 3.83K 1% .125W
A2S1	3101-1973	1	SWITCH SL 7-1A DIP .1A
A2T1	0955-0263	1	180 DEG POW DIV 2 WY PC MINI PSCJ-2-1
A2T2	0960-0622	1	0 DEG POW DIV 2 WY PC MINI PSC-2-1
A2U1	1820-0618	1	IC BUF TTL NON-INV HEX **SN7417N
A2U2	1858-0086	2	TRANSISTOR ARRAY DUAL PNP NPN **MPQ6700
A2U3	1826-0961	2	OP AMP LOW-BIAS-H-IMPD 8-DIP-P PKG*LF411
A2U4	1826-0961		OP AMP LOW-BIAS-H-IMPD 8-DIP-P PKG*LF411
A2U5	1858-0086		TRANSISTOR ARRAY DUAL PNP NPN **MPQ6700
			MISCELLANEOUS A2 PARTS
	0380-0311	1	STANDOFF-RVT-ON .5-IN-LG 6-32 THD

Table 5-3. Chassis and Miscellaneous Parts.

Reference Designation	HP Part Number	Qty	Description
CHASSIS PARTS			
C1	0160-4281	2	CAP-FXD 2200PF +-20% 250VAC (RMS)
C2	0160-4281		CAP-FXD 2200PF +-20% 250VAC (RMS)
F1A	2110-0234	1	FUSE .1A 250V TD (FOR 220/240V OPER)
F1B	2110-0235	1	FUSE .2A 250V TD (FOR 100/120V OPER)
S1	3101-1261	1	SWITCH PF SPDT MOM 1A 115AC
S2	3101-1234	1	SWITCH-SL DPDT-NS STD 1.5A 250VAC SLDR
W1	8120-0616	1	CABLE ASSY 26AWG 16-CNDCT
XF1	2110-0564	1	FUSE HOLDER BODY 12A MAX FOR UL
MISCELLANEOUS PARTS			
	0362-0187	1	CAP-WIRE TERMINAL
	0380-0644	2	STANDOFF-HEX .327-IN-LG 6-32
	1251-2357	1	CONNECTOR-AC PWR HP-9 MALE FLG-MTG
	1400-0017	2	CABLE CLAMP
	1400-0090	1	FUSE HOLDER RUBBER WASHER
	2110-0565	1	FUSE HOLDER CAP 12A MAX FOR UL
	2110-0569	1	FUSE HOLDER COMP. NUT; THREAD M12.7
	2200-0141	3	SCREW-MACH(HEAT SINK) 4-40 .312-IN-LG
	2200-0528	2	SCREW-MACH(TRANSFORMR) 4-40 1.875-IN-LG
	2420-0022	6	NUT-SPCLY 6-32 THD .23 IN-THK .354-OD
	3101-1820	1	CAP-PUSHBUTTON WHITE .2IN-DIA .155-IN-LG
	5040-0270	2	LAMP HOLDER-WHITE
	5080-0098	1	SERIAL PLATE
	7120-3760	1	LABEL-INFO 3-IN-WD 5-IN-LG AL
	7120-4006	1	LABEL-WARNING .4IN-WD 3.15-IN-LG
	7120-4835	1	LABEL-INFO .75-IN-WD 2-IN-LG VINYL
	7120-8732	1	LABEL-WARNING 2-IN-WD 3-IN-LG MYLAR
	7122-0058	1	PLATE-SER .5-IN-WD 1.5-IN-LG AL
	8120-1378	1	POWER CORD SET 18AWG 3-COND 90-IN-LG
	59307-00004	1	BRACKET-SWITCH
	59308-60007	1	STRAP-GROUND 2-IN

**HP J06-59992A Time Interval Calibrator
Replaceable Parts**

Table 5-4. Cabinet Parts.

Reference Designation	HP Part Number	Qty	Description
	5040-7203	1	TRIM, TOP
	59992-00001	1	PANEL, FRONT
	59307-00002	1	PANEL, SUB
	5021-5813	1	FRAME, FRONT
	5001-0438	2	TRIM, SIDE
	5040-7201	4	FOOT
	5040-7209	1	COVER, BOTTOM
	59307-00005	1	BRACKET, MOUNTING
	5040-7212	2	COVER, SIDES
	59992-00002	1	PANEL, REAR
	5040-7208	1	COVER, TOP

5-3. COMPONENT LOCATORS

The component locators for the A1 VHF Switch Control Board and the A2 VHF Switch Board are displayed on the next two pages.

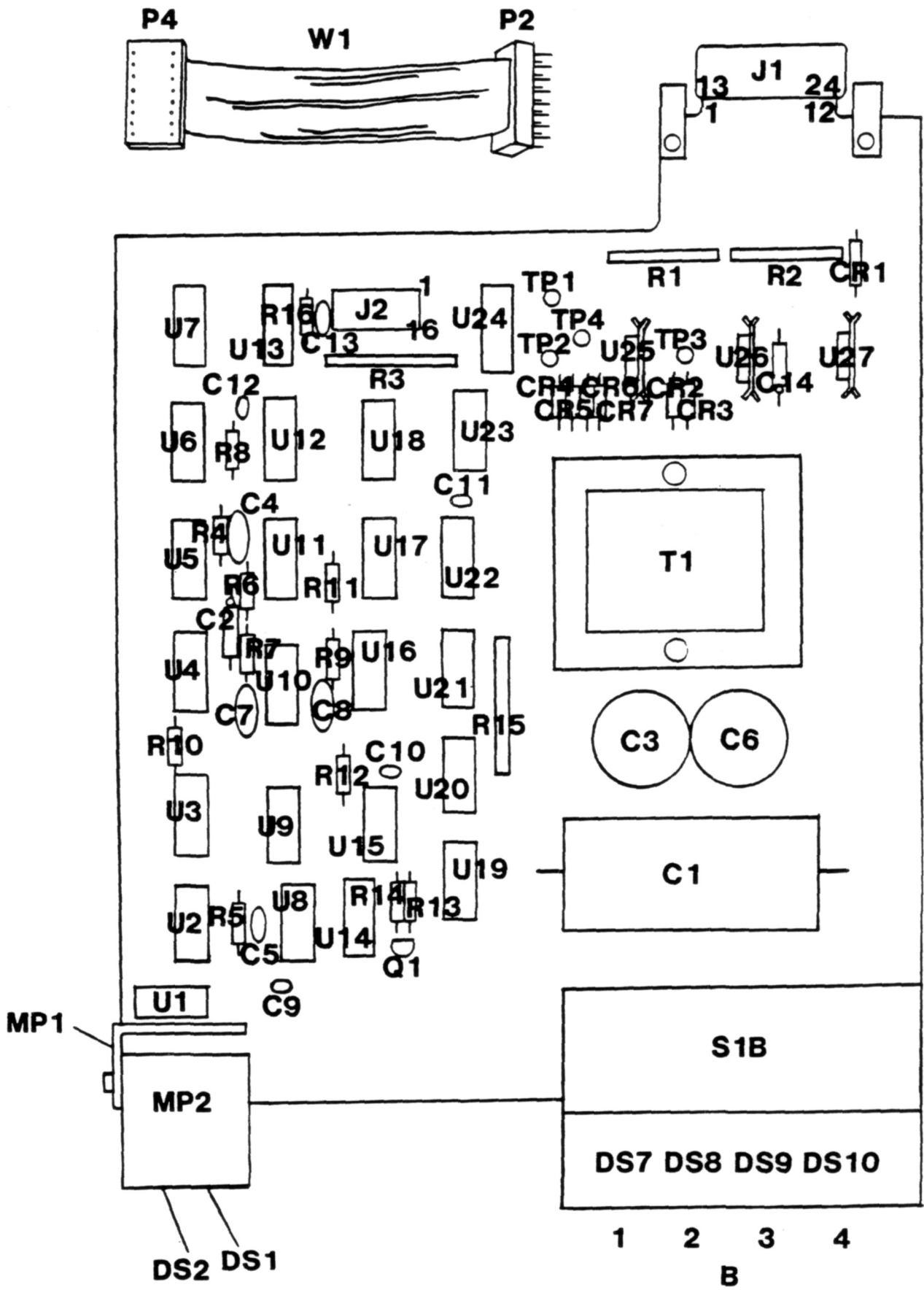

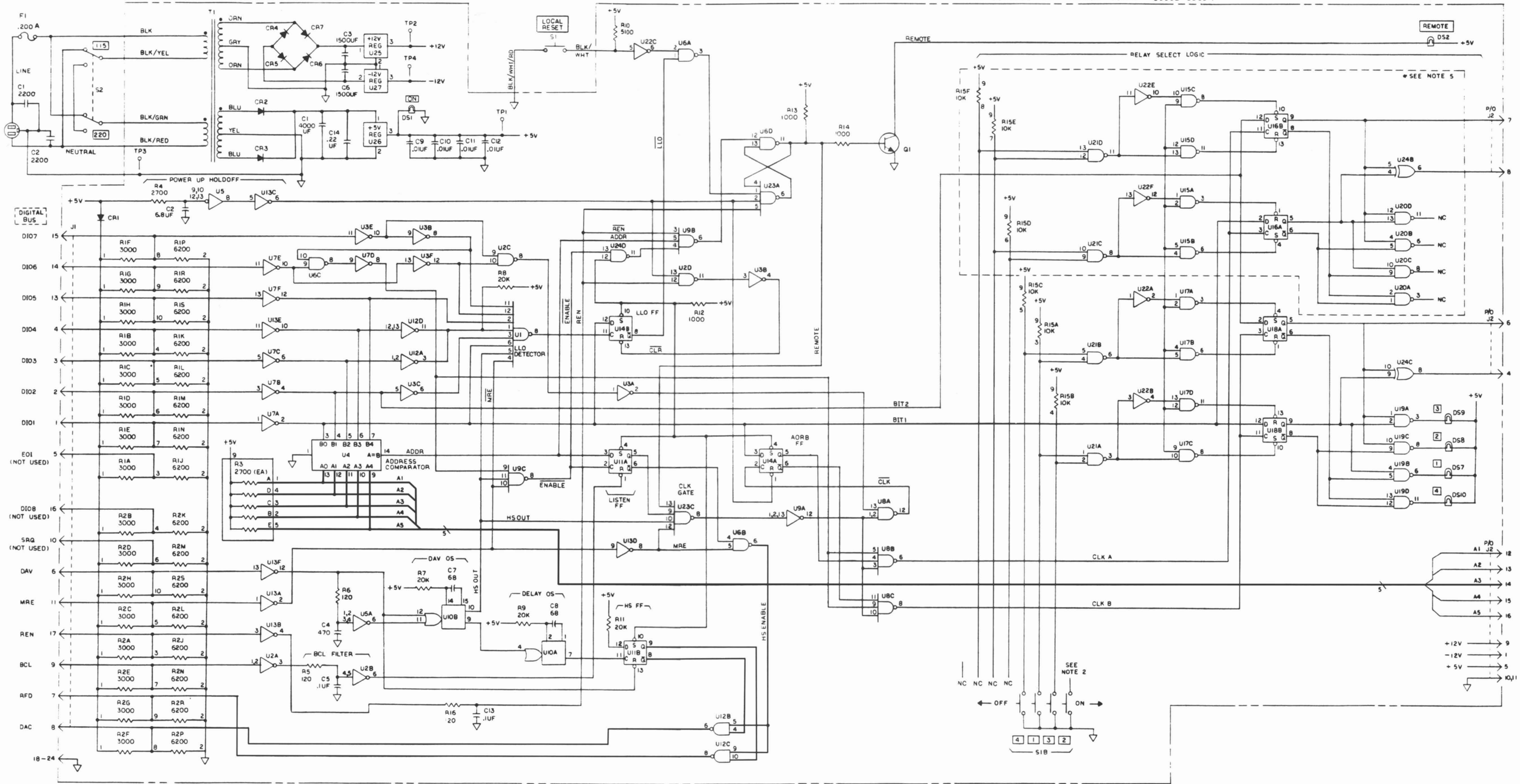

- NOTES
- DS7 THRU DS10 ARE PART OF SWITCH INDICATOR B [] THRU B [] RESPECTIVELY.
 - SWITCH AIS1B IS A 4-STATION PUSHBUTTON SWITCH WHICH IS GANGED SO THAT WHEN ONE OF THE 4 STATIONS IS CLOSED THE OTHER 3 STATIONS ARE OPEN.
 - REFERENCE DESIGNATIONS WITHIN THIS ASSEMBLY ARE ABBREVIATED. ADD ASSEMBLY NUMBER TO ABBREVIATION FOR COMPLETE DESCRIPTION.
 - UNLESS OTHERWISE INDICATED: RESISTANCE IS IN OHMS; CAPACITANCE IS IN PICOFARADS.
 - THIS SECTION OF SCHEMATIC IS NOT USED IN THE J06-59992A THEREFORE U15, U16 & U20 ARE NOT INCLUDED ON THE BOARD. THIS BOARD IS DUAL PURPOSE - ALL COMPONENTS ARE USED ON THE 59307A.
5. FRONT VIEW OF U25 AND U26
- FRONT VIEW OF U27

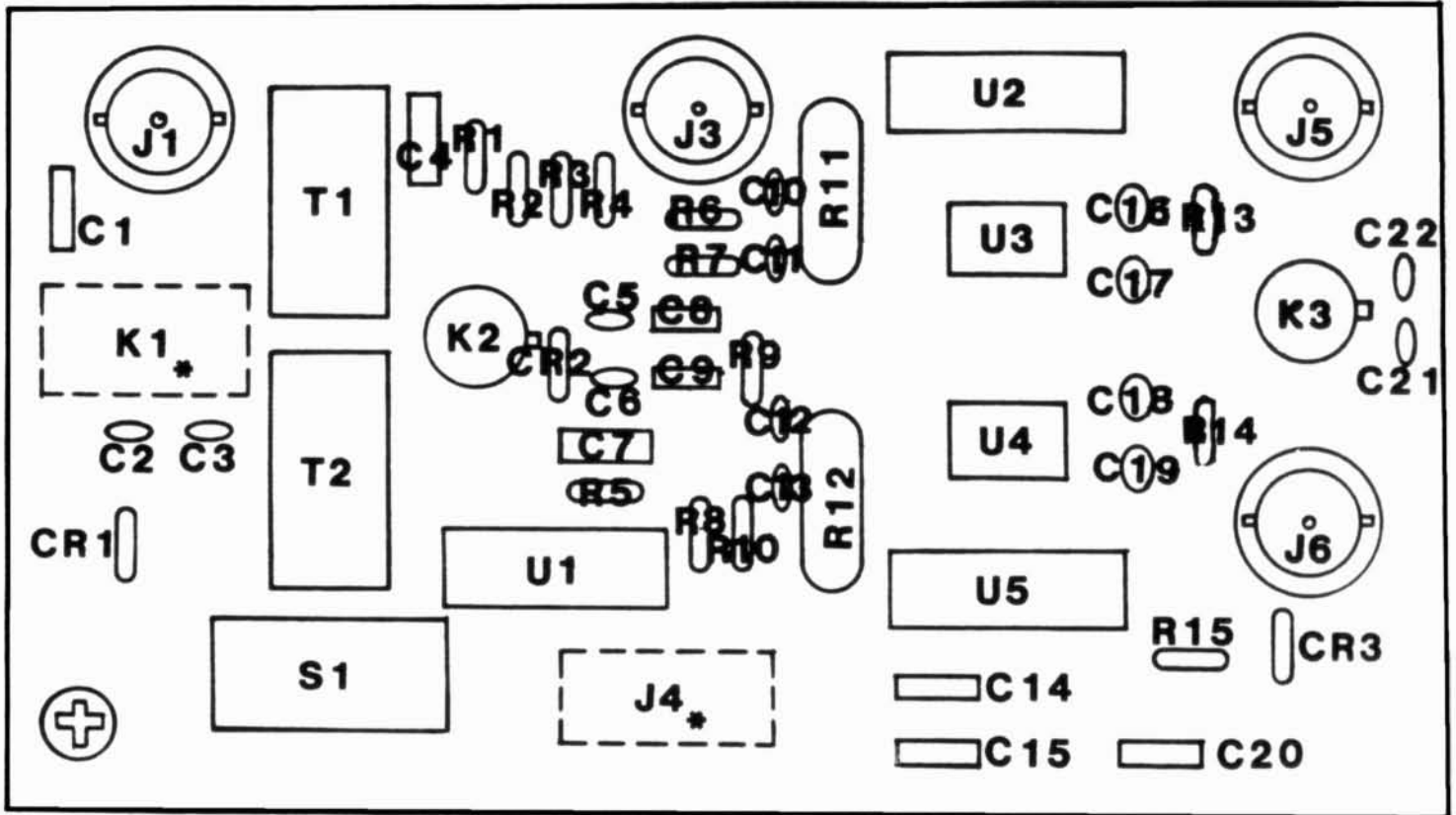

* K1 & J4 LOCATED ON BACK SIDE OF BOARD

A2 (59992-60002) COMPONENT LOCATOR

A2 VHF SWITCH BOARD (59992-60002)

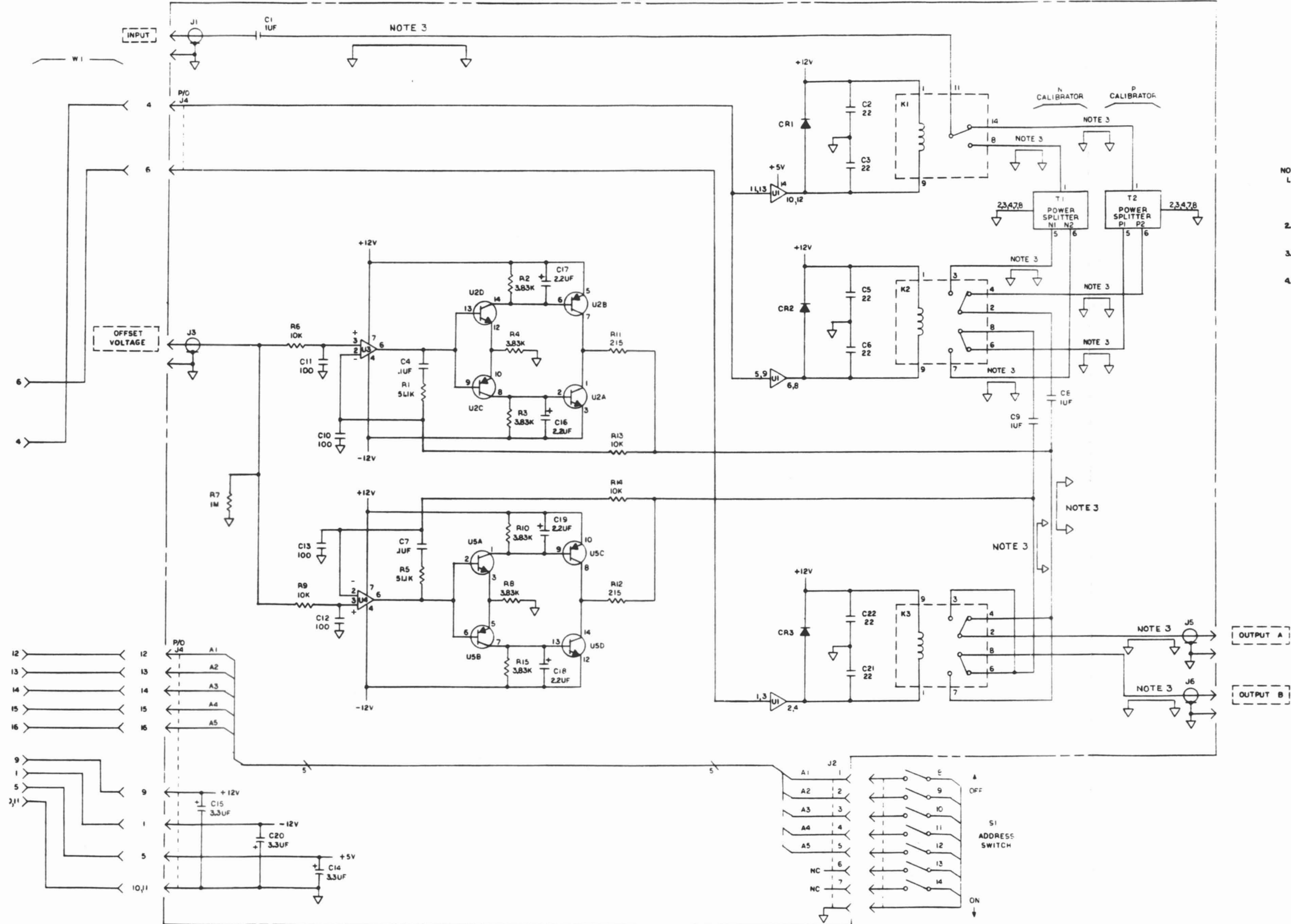

- NOTES
1. REFERENCE DESIGNATIONS WITHIN THIS ASSEMBLY ARE ABBREVIATED. ADD ASSEMBLY NUMBER TO ABBREVIATION FOR COMPLETE DESCRIPTION.
 2. UNLESS OTHERWISE INDICATED: RESISTANCE IS IN OHMS; CAPACITANCE IS IN PICOFARADS.
 3. THIS SYMBOL  REPRESENTS A 50Ω STRIPLINE.
 4. RELAYS ARE SHOWN IN THE DE-ENERGIZED POSITION.

SWITCH	1	2	3	4
OUTPUT A	P1	P2	N1	N2
OUTPUT B	P1	P2	N1	N2
J4 PIN 4	H	H	L	L
J4 PIN 6	L	H	H	L



MANUAL PART NUMBER 59992-91094

www.hparchive.com

PRINTED IN U.S.A.